

Chapter 3

CONVEYING

In the paddy postharvest system, paddy is moved, transported, or conveyed from place to place. Traditionally, these have been hand operations. After harvest the paddy is placed in gunny bags and transported several times through storage and processing before the milled rice finally reaches the consumer. Paddy is often handled too much, resulting in high handling costs and excessive losses.

More and more paddy is being handled by mechanical conveyors. Some conveyors replace hand labor; others supplement it or enable the same labor to move or handle more paddy. Different types of conveyors are used. Screw and belt conveyors move paddy horizontally or up small inclines. In some cases, chain and vibrating conveyors are used. Bucket elevators are most common for lifting paddy vertically, but occasionally inclined screw conveyors are used.

Paddy is a highly abrasive material and causes excessive and rapid wear on screw, chain, and pneumatic conveyors. For this reason, bucket elevators and belt conveyors (both using rubber-covered belts) are preferred. They wear longer and are thus usually the most economical. Vibrating conveyors have been used in certain parboiling systems — mainly to permit excess water from the parboiling tanks to drain off before the paddy enters the drying system.

When bulk paddy is handled, mechanical conveyors instead of hand labor are required. In Sri Lanka in 1978, the conveying equipment for a 3,000-ton bulk store cost \$17,420. It replaced labor, which cost \$2,630 a year. Therefore, the investment cost of the mechanical conveyors was paid off in less than 7 years. Although there are many other factors to consider, this illustrates the cost of mechanical conveyors vs labor.

This chapter deals with the more popular and economical types of paddy conveyors. They include bucket elevators, belt and screw conveyors, and associated equipment such as grain valves and spouting.

BUCKET ELEVATORS

General description

A bucket elevator consists of buckets attached to a chain or belt that revolves around a bottom pulley (allowing the buckets to fill with paddy) and a top pulley where the buckets discharge their paddy. The vertical lift may be a few meters to more than 50 m. Capacity may vary from 2 to 4 t/hour to as much as 25, 50, or even 100 t/hour. A typical bucket elevator with details is shown in Figure 3.1.

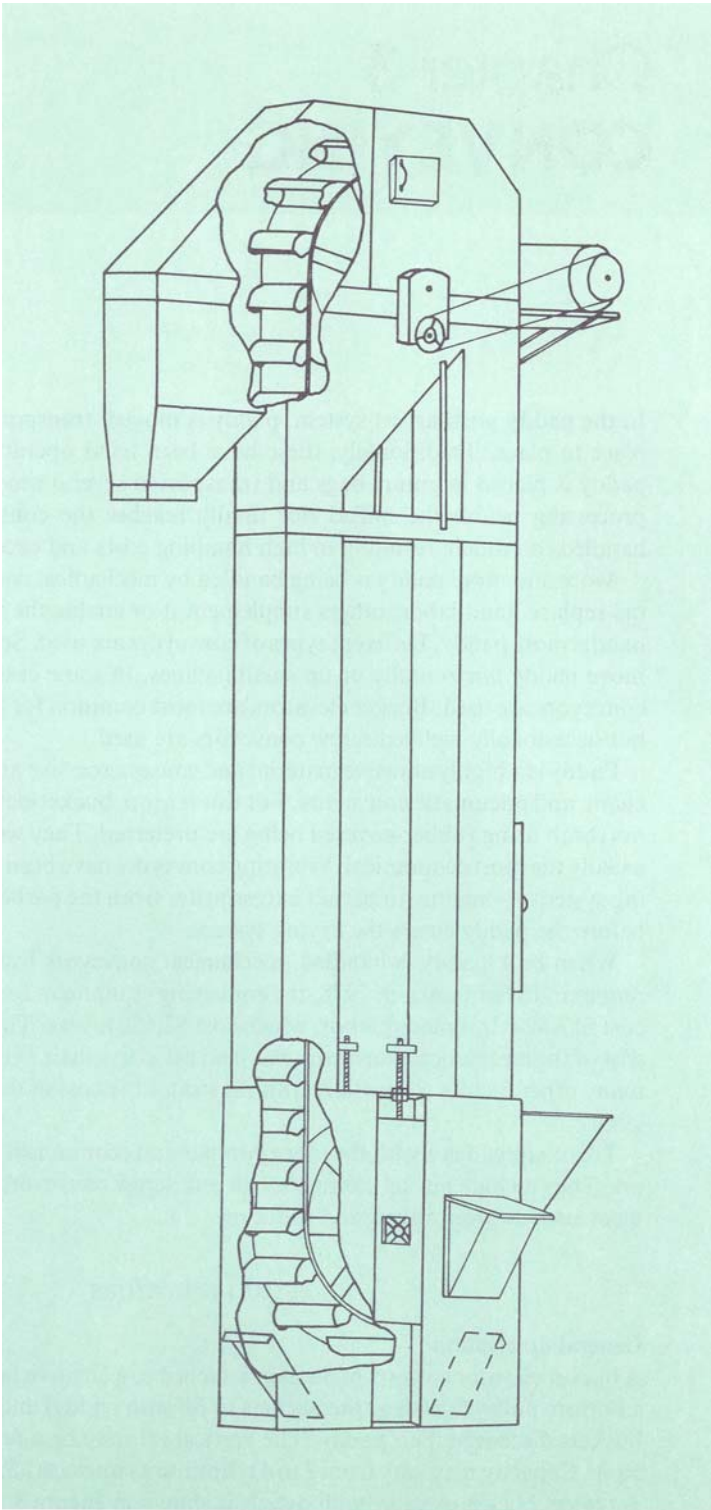

3.1. Typical bucket elevator.

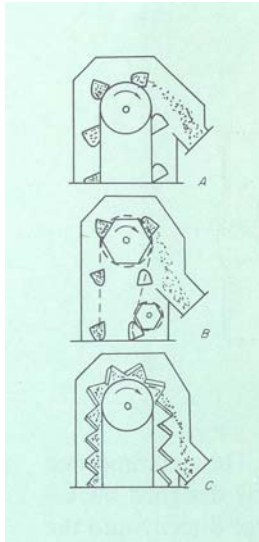

3.2. Elevators discharging paddy: A, centrifugal; B, gravity; C, direct gravity.

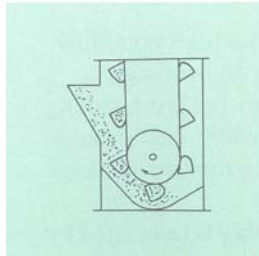

3.3. Loading paddy into the boot of an elevator.

3.4. Bucket used for centrifugal discharge elevator. (Courtesy of Screw Conveyor Corp.)

Types

Bucket elevators are available in several designs to handle many products. They are classified according to the type of discharge used and are identified as centrifugal, positive (gravity), and continuous (direct gravity). The three types are shown in Figure 3.2. The centrifugal discharge type is most commonly used with grains. It is designed and engineered to conform with general practice in handling grain. Head and boot shafts are provided with roller bearings. Takeups are generally screw-type except on tall high-capacity units where gravity-type take-ups are more common. Buckets are usually made of steel or plastic and are bolted onto the belt. Casings or legs are also made of steel, are welded or bolted together, and are dusttight. The curved hood is designed for proper centrifugal discharge of the paddy grain. The boot can be loaded from the front or back or both (Fig. 3.3). In larger, high-capacity installations the head section is often vented and connected to an aspiration system.

Bucket types and capacities

Buckets are made of different materials and come in different shapes and sizes, depending on requirements. Figure 3.4 shows a typical bucket used with centrifugal discharge elevators. The buckets are uniform, smooth, and proportioned for fast filling and quick, clean discharge. Figure 3.5 shows the correct method of bolting the bucket to the belt.

Dimensions and capacities of different buckets are given in Table 3.1. The carrying capacity is based on the angle of repose of paddy, which is normally 36° (see line x - x in Fig. 3-4.) Because of the difficulty of loading all buckets to 100% of rated capacity and the desirability of having a small reserve capacity in the elevator, designers calculate carrying capacity on the basis of buckets being filled to 85 to 90% of rated capacity.

Bucket spacing or the minimum vertical spacing between bolt holes of elevator buckets is also shown in Table 3.1. Buckets may be as far apart as the required capacity permits. Installing buckets closer than the minimum will probably result in reduced carrying capacity because they will not fill properly at the recommended belt speed.

Elevator capacities

The bucket elevator's capacity in tons of paddy per hour depends on bucket size and spacing and on belt speed. Speed is the first critical factor to consider. The speed of

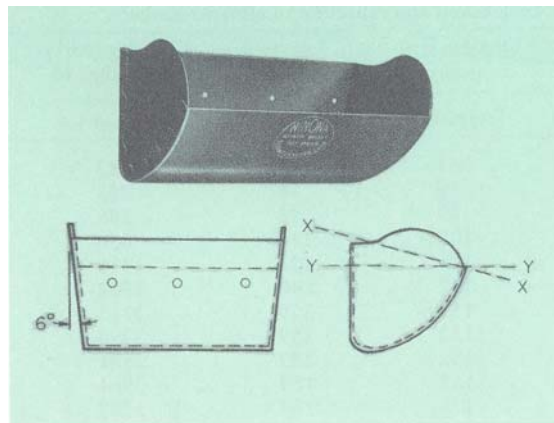

3.5. Correct method of bolting the bucket to the belt.

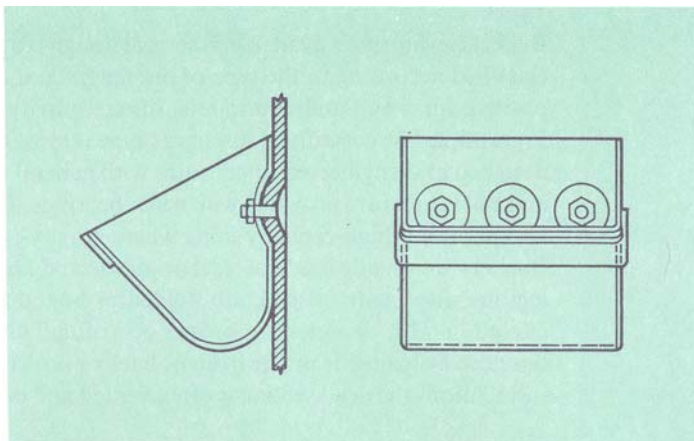

the belt in meters per minute depends on the head pulley speed. The recommended head pulley speed depends on the pulley diameter. A properly designed bucket elevator driven at the correct speed will make a clean discharge directly into the throat of the head liner ensuring only slight paddy damage and little or no backlegging or downlegging. If the head pulley speed is too slow, the buckets spill the paddy into the legs. Paddy breakage occurs when the paddy is tumbled within the pulley and re-elevated, as shown in Figure 3.6(A).

The optimum speed is shown in Figure 3.6(B). The buckets fill and carry optimally and discharge the paddy directly into the throat — no spillage, no breakage.

If the head pulley speed is too fast, paddy is damaged by rough and fast handling and the buckets will not fill properly. The buckets lose all their holding and discharge control (Fig. 3.6(C)). The result is inefficient operation as well as excessive breakage and undue head wear of the elevator top.

For optimum centrifugal discharge, the speed of the head pulley is calculated by

$$RPM = \frac{29.9}{\sqrt{R}}$$

where R is the radius of the wheel plus one-half the projection of the bucket in meters. Experience has shown that for paddy and most lightweight grains, a more

Table 3.1. Dimensions and capacities of elevator buckets.

Length	Bucket size (mm)		Capacity (cm ³) when filled to line x-x in Figure 3.4	Normal spacing on belt (mm)
	Projection	Depth		
76	64	64	142	102
102	70	76	283	102
127	89	95	566	127
152	102	114	850	152
178	114	127	1416	165
203	127	140	1982	178
229	152	159	3115	203
254	152	159	3398	203
279	152	159	3681	203
305	152	159	3964	203
305	178	184	5380	229

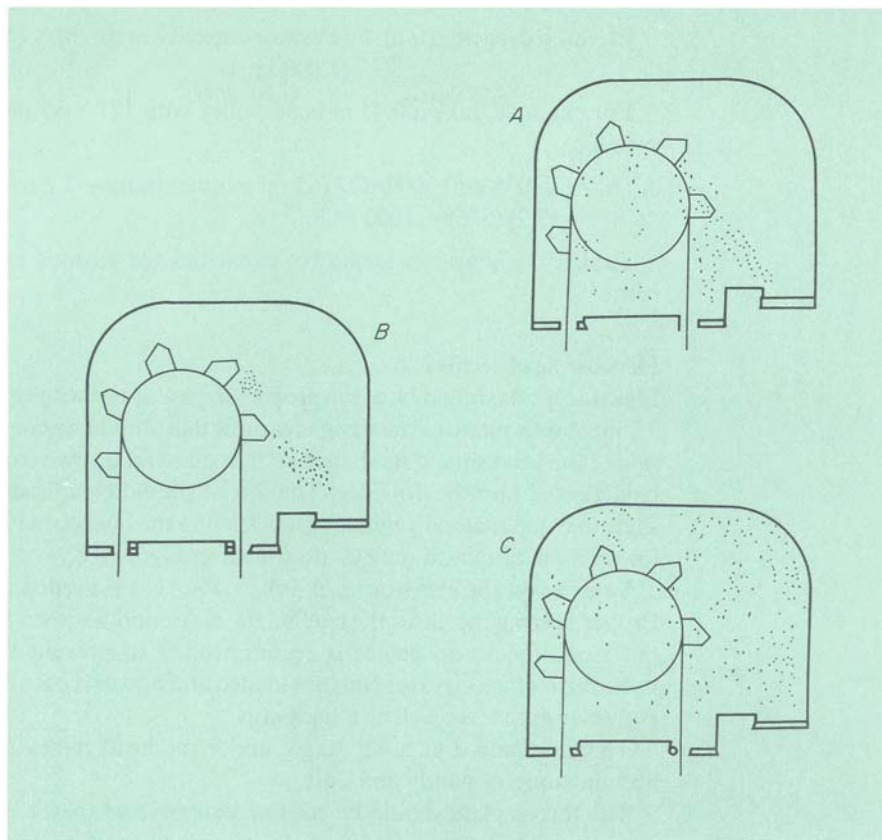

3.6. Elevator discharge at different bucket speeds: A, too slow; B, optimum, C, too fast.

satisfactory operational speed is 80 to 85% of the theoretical speed. Table 3.2 shows the recommended elevator speeds for different pulleys.

Thus, elevator capacity may be calculated from 1) bucket capacity and recommended spacing found in Table 3.1, and 2) belt speed found in Table 3.2 as follows:

$$\text{Elevator capacity (m}^3/\text{h)} = (\text{bucket capacity in m}^3/1,000,000) \times (\text{number of buckets per meter of belt}) \times (\text{belt speed in meters/minute}) \times (60 \text{ minutes/h});$$

Table 3.2. Recommended elevator speeds for different size head pulleys.

Pulley diameter (cm)	Pulley circumference (cm)	Average bucket projection (cm)	Head pulley rpm		Recommended belt speed ^a (m/min)
			Calculated	Recommended	
30	94	10	66	56	53
41	129	10	60	51	65
51	160	10	54	46	13
61	192	13	49	42	80
76	239	15	44	31	89
91	286	18	40	34	98
122	383	20	36	31	119

^aBelt speed (m/min) = (3.1416) × (pulley diameter in meters) × (recommended rpm).

3.7. Elevator head showing desired features: A, sprinkler head and alarm; B, strut slanted to down leg; C, cleanout opening; D, inspection door; E, lagged head pulley; F, buckets. Belt should be 2.5 cm wider than buckets, pulley should be 2 cm wider than belt.

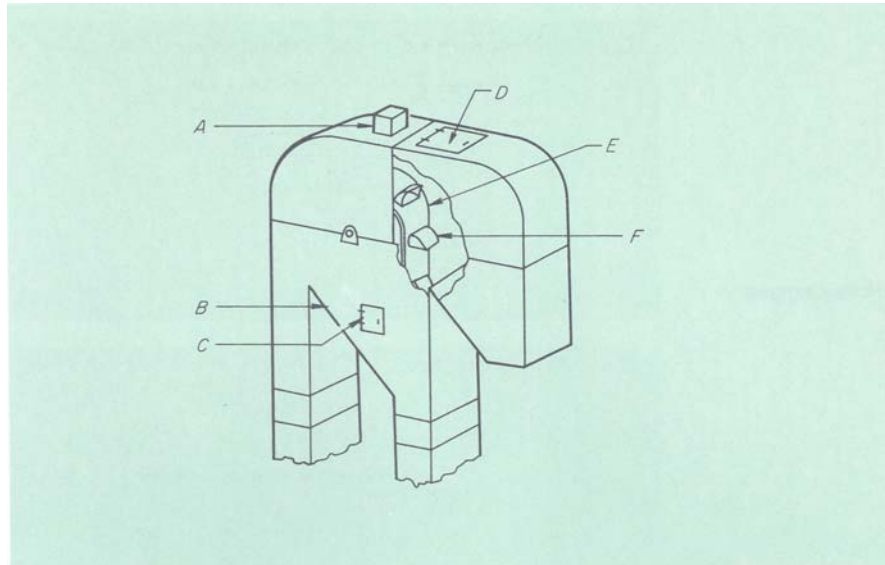

Elevator boot section

Most bucket elevators provide in the boot section a belt take-up device to tighten the belt as required and to train it so that it runs true and does not rub on either side of the boot. A manual screw-type take-up is most often used (Fig. 3.10). On tall, heavy-capacity legs an automatic take-up boot pulley is used. This provides the correct belt tension at all times.

3.8. Head section design details and dimensions.

The offset leg-type elevator shown in Figure 3.11 uses a boot pulley smaller than

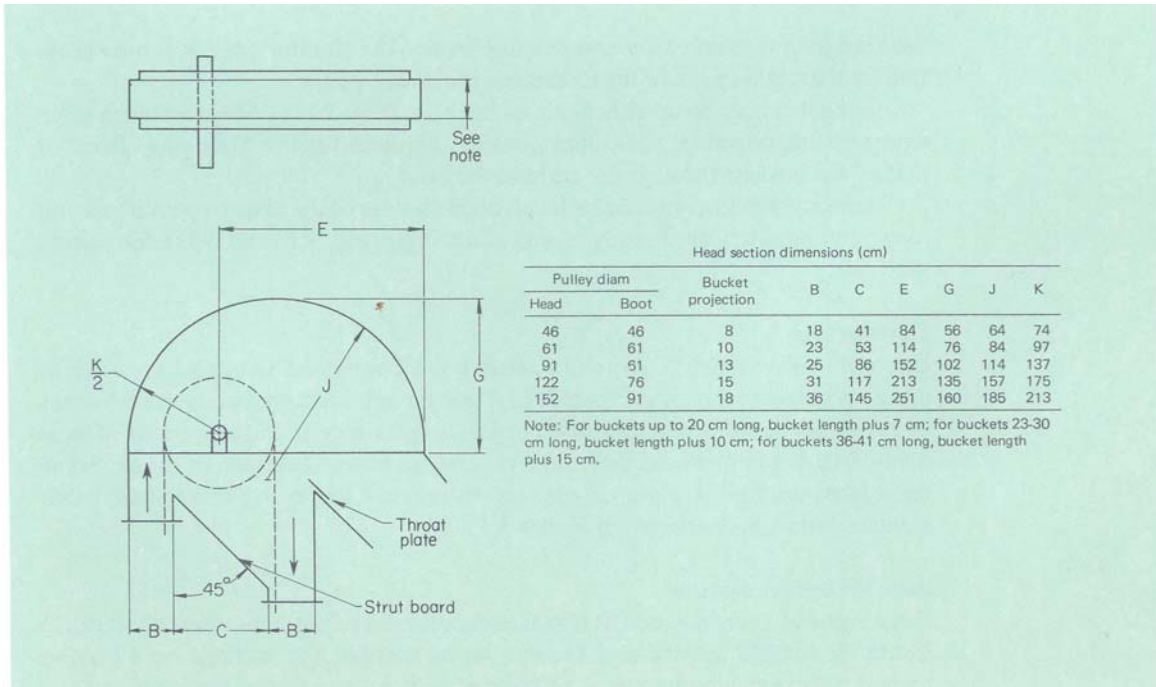

3.9. Pulley lagging.

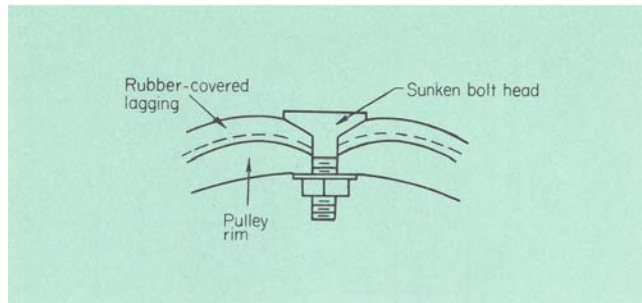

3.10. Elevator boot section with screw take-up adjustment.

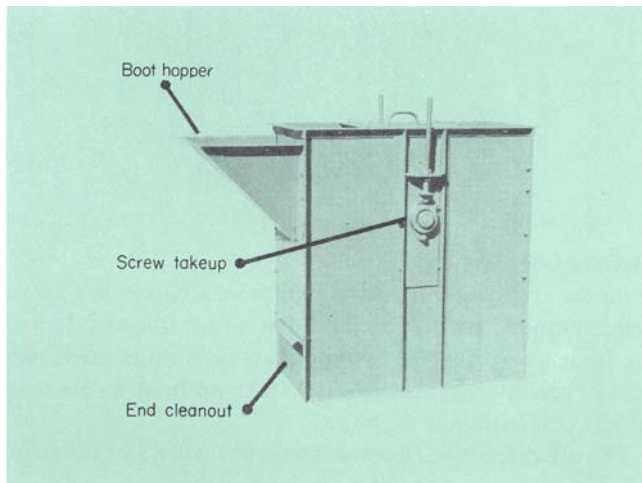

the head pulley, mainly to conserve space around the elevator boot. It should be no smaller than two-thirds of the diameter of the head pulley.

Grain entry may be on either side of the boot (Fig. 3.11). However, when grain enters on the downleg, additional power is required for the “dredging effect” of pulling the buckets through the grain in the boot.

Cleanouts should always be included on both sides of the boot to permit fast and easy cleaning. They are usually placed at an angle (Fig. 3.10 and 3.11) and should slide easily.

Elevator legs

Elevator legs are constructed as all welded, bolted, or riveted units. Cross sections of different types are shown in Figure 3.12. They are manufactured in standard lengths of 2.4 m, but could be manufactured in any length desired. The economics of local manufacturing cost should determine which type of leg construction to use. Some manufacturers find it more economical to employ singlebox construction that includes both legs, as shown in Figure 3.13.

Belts for bucket elevator

Four types of belts are used for bucket elevators and belt conveyors: 1) duck, 2) balata, 3) stitched canvas, and 4) solid woven cotton. Any of these belts may be treated with special preparations or covered with natural or synthetic rubber.

8.11. Boot section design details and dimensions.

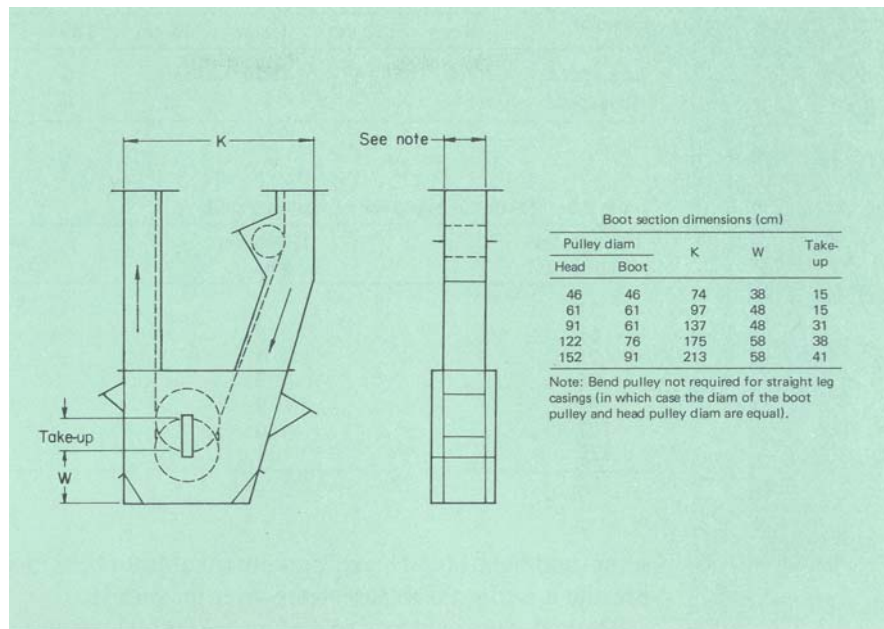

The standard cotton duck belt differs from ordinary sail duck or canvas in that the strength of the warp (lengthwise threads) is considerably greater than that of the weft (crosswise threads). Duck for belts is ordinarily graded as 28 oz, 32 oz, etc., according to the weight of a piece 91 cm long in the warp and 107 cm wide.

Balata belts are made of waterproofed cotton duck belts held together by balata, a tree gum which is stronger than rubber at ordinary temperature but not so elastic.

Stitched canvas belts are multi-ply duck belts whose plies have been stitched together and made waterproof. Solid woven belts are woven to thickness in looms and are not of multiple construction. They are used primarily for power transmission.

Most conveyor and elevator belts are of folded-ply construction. Some belts are made by building up layers of plies that are cut or woven to the width desired and are called "plied" construction belts. Table 3.4 shows minimum plies used in elevators. The leverage on the bucket heads, due to the digging action and the load, increases with greater bucket projections so that more plies are required to keep the bolts from pulling through the belt.

Belt selection also depends on pulley diameters. Table 3.5 shows maximum plies for standard pulley diameter.

The type of belt splice depends on the thickness of the belt and the severity of service. For belts of five-ply thickness or less, the bolted clamp joint, the lap joint, or the buttstrap joint may be used (Fig. 3.14).

For the clamp joint, belt ends must be bent outwards at right angles to form a ridge that is then bolted between a bar clamp. On a lap joint splice, the lap extends a distance of three to five buckets and is secured by the same bolts that hold the buckets. (Use 20 mm bolts on four-ply belts, 25 mm for five- and six-ply, 32 mm for

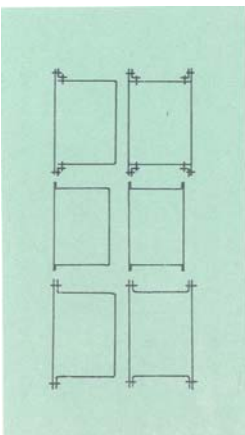

3.12. Cross don of different types of elevator legs.

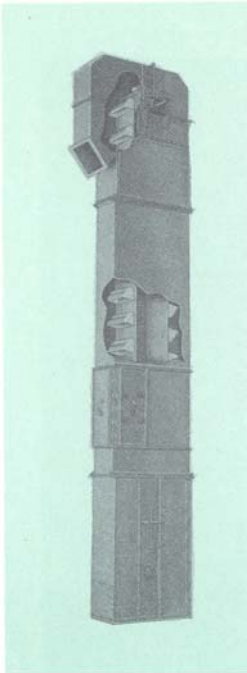

3.13. Singlebox type elevator leg.

Table 3.4. Minimum plies for bucket projections

Grain elevator	Minimum plies when bucket projection is						Belt fabric
	8 cm	10 cm	13 cm	15 cm	18 cm	20 cm	
Low-speed	4	4	5	5	6	6	28 oz or 32 oz
High-speed	-	-	-	5	6	6	32 oz

Table 3.5. Maximum belt plies vs diameter pulleys.

Head pulley diam (cm)	Maximum plies	Minimum foot pulley diam (cm)
51	5	38
61	6	46
71	7	53
76	8	56
91	9	66
107	10	76
122	12	91

seven- and eight-ply.) This splice is not suitable for belts more than seven plies thick because it is too stiff to pass tightly over the pulleys.

The butt-strap joint may be used on belts of eight or more plies. Place one bolt for each 25 mm of belt width, 10 mm bolts for belts less than 10 plies, and 15 mm bolts for those more than 10 plies.

Belt widths should be the bucket width, plus 25 mm. The pulley width should be the belt width, plus 25 mm or more.

Accessories

For servicing the elevator head section, particularly the drive mechanism, a platform for working is needed. Access to this platform is usually by ladder equipped with a safety cage. A typical elevator with platform is shown in Figure 3.15. In some installations, joint or common ladders are used for two or more elevators or other machines.

3.14. Splicing elevator belts.

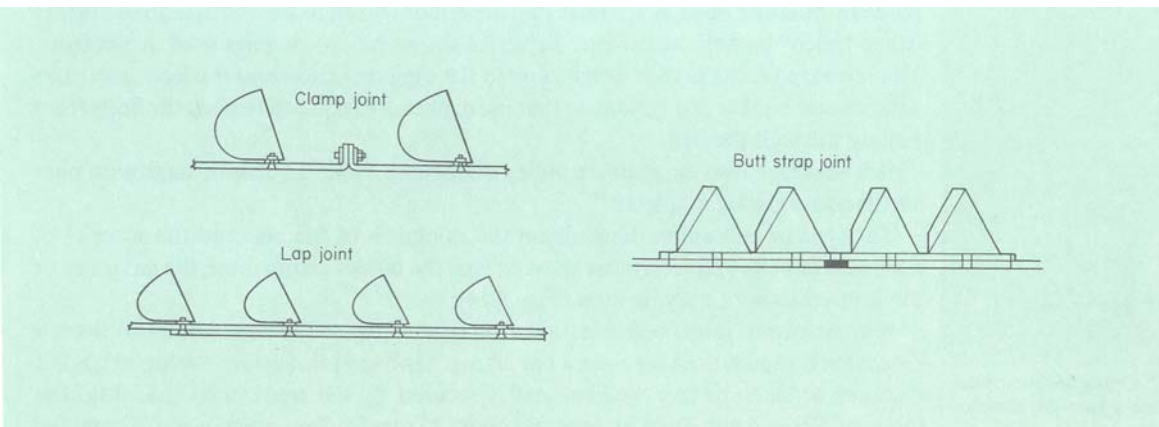

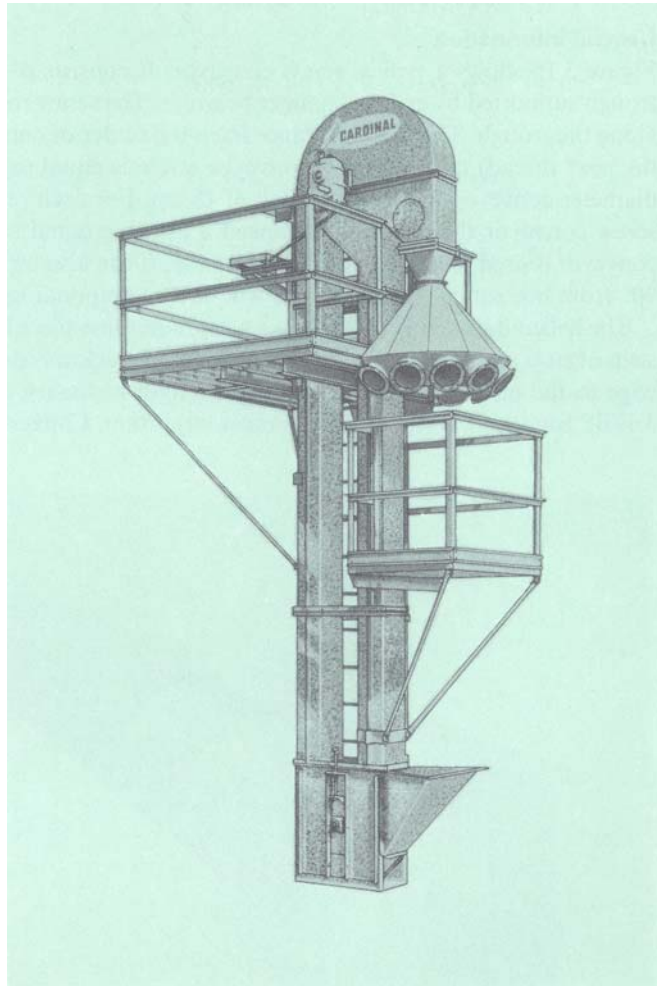

3.15. Elevator with platform, ladder, and safety cage. (Courtesy of Cardinal Division, LML Corp.)

Power requirements

The theoretical horsepower (hp) requirements for bucket elevators may be obtained from the equation:

$$hp = \frac{Q H F}{4562}$$

where Q = capacity in kilograms per minute, H = lift in meters, and $F = 1.5$ for elevators loaded on the down side of the boot, 1.2 for elevators loaded on the up side of the boot. Actual horsepower requirements are 10 to 15% higher than this theoretical value because of friction, power transmission, and drive losses. For example, horsepower requirements for a bucket elevator with 1,600 bu/h of paddy and a lift of 10.7 m loaded on the up side would be: (1,600 bu/h = 545 kg/minute)

$$hp = \frac{545 \times 10.7 \times 1.5}{4562} = 1.9 \text{ plus } 15\% = 2.19$$

Therefore the next larger standard size electric motor should be selected.

SCREW CONVEYORS

General information

Figure 3.16 shows a typical screw conveyor. It consists of a conveyor screw in a trough supported by end and hanger bearings. The screw rotation pushes the grain along the trough. The pitch (distance from the center of one thread to the center of the next thread) of a standard conveyor screw is equal to its diameter. A 15-cm diameter conveyor screw has a pitch of 15 cm. For each revolution of a standard screw conveyor the paddy is advanced a distance equal to the pitch. The screw conveyor is used to move paddy horizontally. It can also be used at any angle up to 90° from horizontal although there will be a corresponding reduction in capacity.

The helicoid screw (Fig. 3.17A) is a continuous one-piece helix shaped from a flat strip of steel and attached to a pipe or shaft. Its thickness decreases from the inner edge to the outer edge because of the strength necessary to form the helix (Fig. 3.17B). Smoothness of the helix is most important. Capacities and power require-

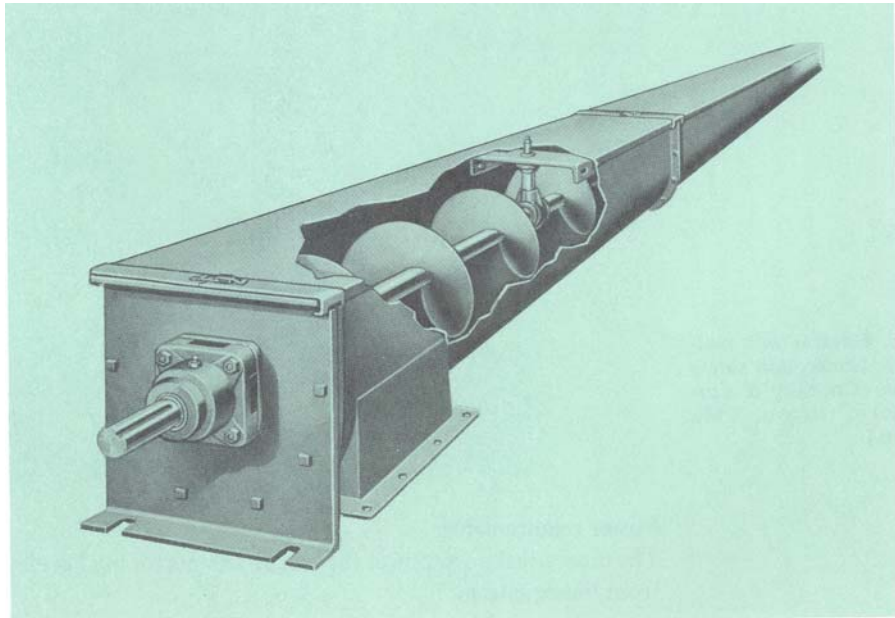

3.16. Typical screw conveyor.

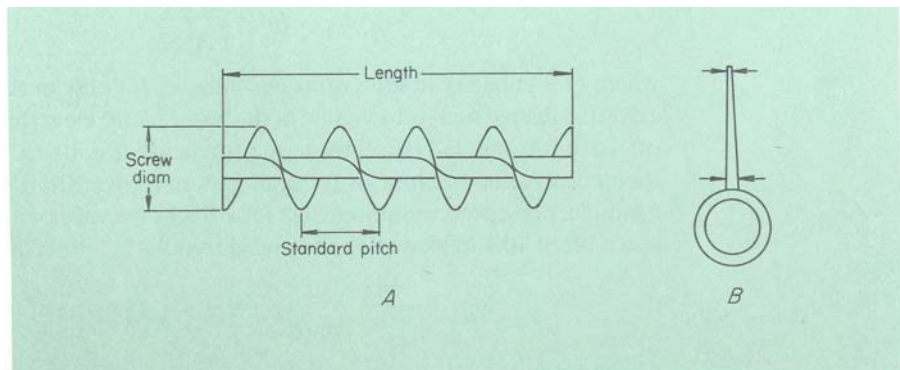

3.17. Helicoid conveyor screw section.

ments vary with segmented or welded sections.

Paddy is much more abrasive than most other grains and causes excessive wear on the flights as well as the trough. To reduce wear, flights (helicoid section minus the shaft) may be fabricated from various materials such as stainless steel, monel, or copper alloys. But because these materials are generally too expensive, a high-carbon steel or other less expensive abrasive-resistant alloy is used.

A number of other conveyor flights are designed for special purposes. The ribbon screw conveyors convey sticky materials. Another special type is a short-pitch conveyor — pitch may be one-half of screw diameter or less — generally used in feeders (Fig. 3.18). The short-pitch conveyor is used under a dump pit where full loading of the screw is expected.

Screw conveyors may be designed for clockwise or counterclockwise rotation without change in capacity. The screw conveyor carries the material as seen in Figure 3.19, on opposite sides (right-hand or left-hand). This characteristic may be considered in certain installations, such as feeding an elevator or machine.

Sizes and capacities

Screw conveyor components, in addition to the screw, include end bearings, hanger bearings, inlet openings, and discharge openings (see Fig. 3.20 for details and general dimensions). The dimensions of the helicoid screw are given in Figure 3.21.

Paddy assumes a cross section loading of 30% during operation of a screw conveyor as shown in Figure 3.22. Based on this loading factor, screw diameter, and rpm, the capacity for standard size screw conveyors is shown in Figure 3.22. For screw conveyors of standard construction, the capacity chart should always be followed for recommended maximum speeds. Speeds selected below the maximum recommended are conservative. Speeds above that should be referred to the manufacturer before they are used.

From Figure 3.22 for example, a 15-cm conveyor at maximum speed of 120 rpm has a capacity of 5.10 m³/hour. With paddy of 576 kg/m³, this is 2,937 kg or about 3.0 t/hour.

(This is 39% of the theoretical calculated capacity based on the formula $Q = (D^2 - d^2) / 36.6 \times P \times rpm$, where Q is in ft³/hour, D = screw diameter in inches, d = shaft diameter in inches, and P = pitch in inches. Because of screw housing clearance and the loading factor, the actual capacity is less than the theoretical capacity.)

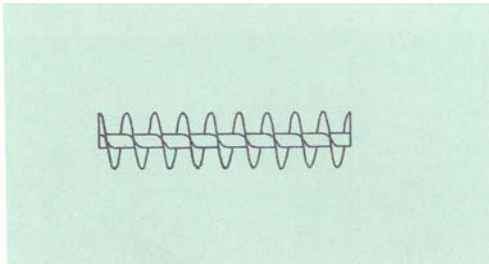

3.18. Short pitch conveyor section.
(top)

3.19. Conveyor screw sections: A and B, right-hand; C and D, left-hand.
(right)

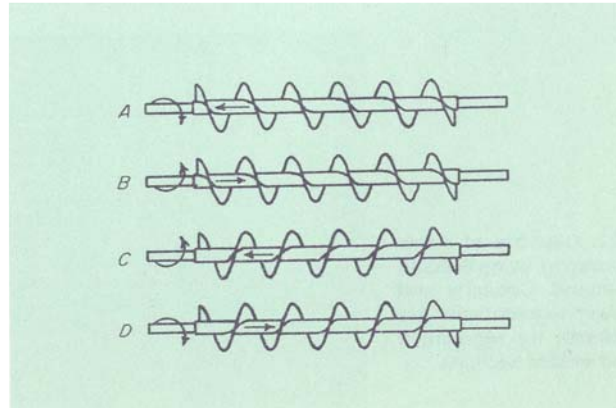

3.20. Schematic and dimensions for screw conveyor. (top)

3.21. Helicoid flight conveyor screw and dimensions (pitch = screw diam). (bottom)

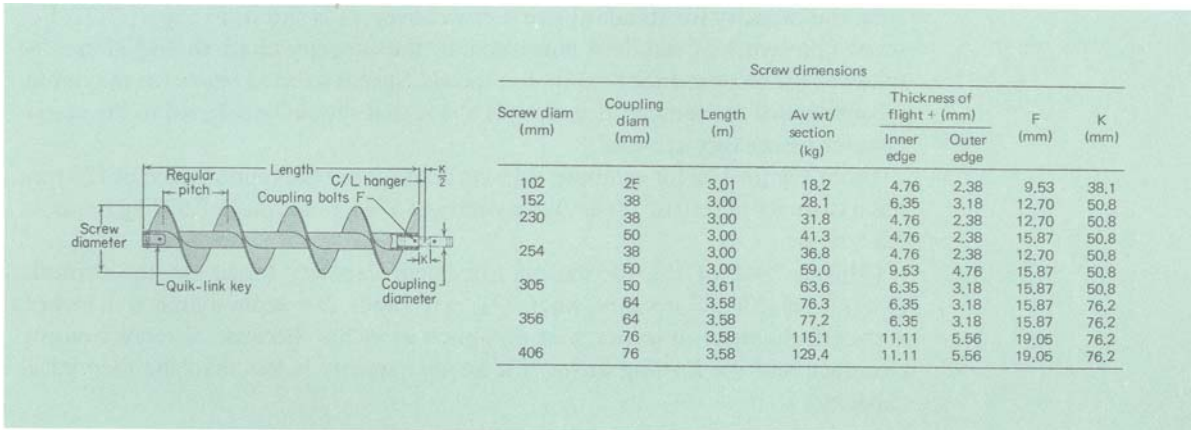
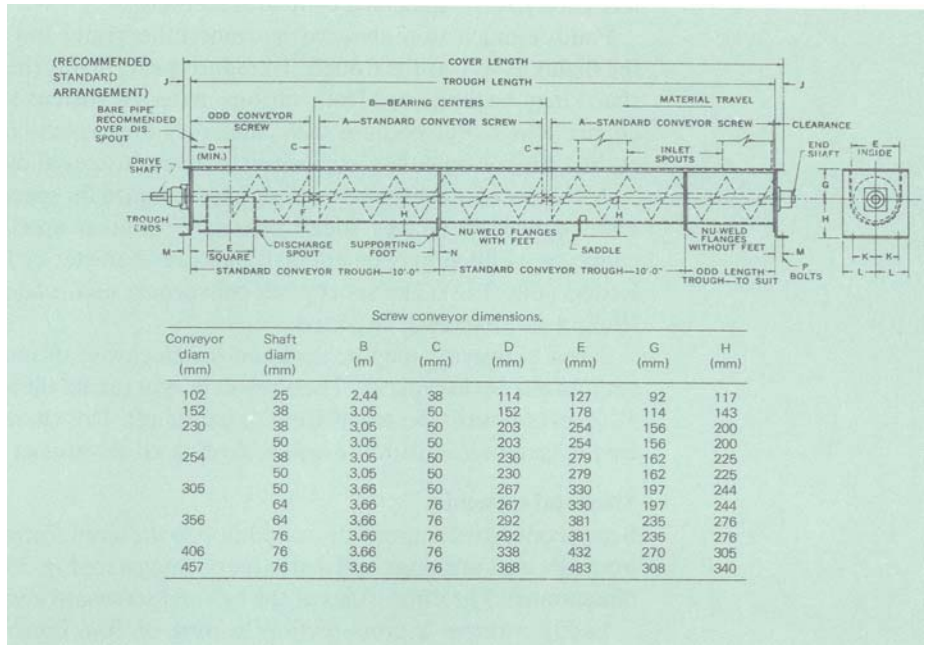

3.22. Capacity of screw conveyors using helicoid sections. Capacity and power requirements are different for segmented and welded sections.

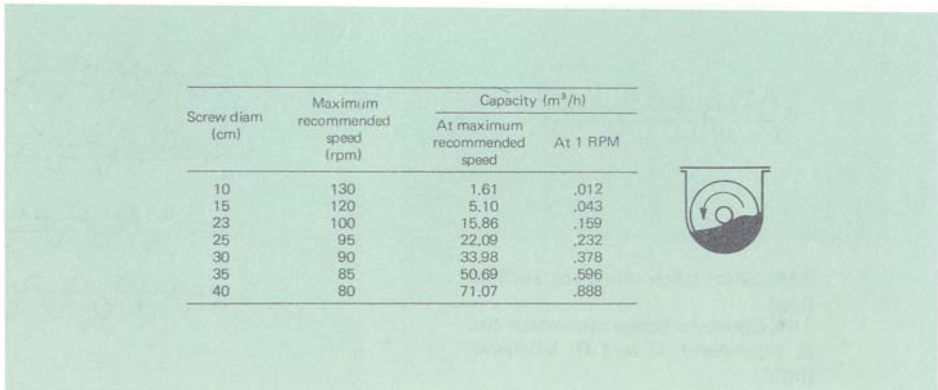

Horsepower requirements may be determined by using the following formulas. The determination does not consider power loss in drive equipment (belts, chains, or gear reducers), imperfect alignment, or the power required for starting under load. Additional power is therefore required for the average installation to overcome drive losses and imperfect alignment.

$$(1) \quad H = L \frac{(DS + QK)}{1,000,000}$$

$$(2) \quad \text{hp} = \frac{H \times P}{0.85}$$

Where L = overall length in feet
 D = factor depending on type of bearings (Table 3.6)
 S = speed in rpm
 Q = quantity of paddy in pounds per hour
 K = material factor, for paddy = 0.4

Where $P = 2$ when H is less than 1
 $P = 1.5$ when H is between 1 and 2
 $P = 1.25$ when H is between 2 and 4
 $P = 1.1$ when H is between 4 and 5
 $P = 1$ when H is greater than 5 and 0.85 is estimated efficiency of the drive

A sample problem:

Determine conveyor size, speed, and horsepower requirements to move 20 t paddy/ hour over a distance of 24 m.

Solution:

From Figure 3.22 $(20 \text{ t/h} \times 1,000 \text{ kg/t}) \div 576 \text{ kg/m}^3 = 34.72 \text{ m}^3/\text{h}$, a 30-cm screw at 92 rpm would be adequate. Then, assuming self-lubricating bronze bearings from Table 3.6, $D = 96$, $H = (24 \times 3.281) \times (171 \times 150 + 44,080 \times 0.4) \div 1,000,000 = 3.41$ then:

$$\text{hp} = \frac{3.41 \times 1.25}{0.85} = 5.01$$

Table 3.6. “D” factors in computing horsepower for screw conveyors.

Conveyor diam (cm)	“D” factor for type of hanger bearings			
	Ball or roller	Wood, babbitt, bronze or molded fabric	Self-lubricating bronze	White iron or manganese steel
7.5	10	15	24	35
10	12	21	33	50
15	18	33	54	80
23	32	54	96	130
25	38	66	114	160
30	55	96	171	250
35	78	135	255	350
40	106	186	336	480

The next standard size electric motor above 5 hp should be used. The following specifications apply:

Conveyor size: 30 cm
 Conveyor speed: 92 rpm
 Conveyor horsepower: 7.5

Screw conveyors can be operated in an inclined position with the flow of materials upward. However, the allowable capacity rapidly decreases as the angle of inclination increases. A standard conveyor inclined 15 degrees will carry about 75% of its rated horizontal capacity. At an incline of 25 degrees it will carry about 50% of its rated horizontal capacity.

The additional horsepower required over the horizontal horsepower requirements is roughly 25% for a 15° inclined conveyor and 50% for a 25° inclined conveyor. For a screw conveyor operated at an incline greater than 25°, a tubular casing or a shrouded U trough should be used. It also becomes necessary at this angle to use shorter-than-standard pitch flights.

Hangars and end bearings

The end thrust on a conveyor screw is against the direction of material flow. An end thrust bearing assembly absorbs this force and prevents excessive wear of the operating parts. A number of thrust arrangements are possible. One of the most frequently used is an outside-type thrust bearing (Fig. 3.23). Preferably, the conveyor drive should be installed to drive through the end thrust because the shaft is fixed in position and cannot “float” in the end bearing. However, the drive is often installed on the feed end of the conveyor because of space or other limitations.

A standard-type hanger bearing used for screw conveyors designed for paddy is illustrated in Figure 3.24. The 3.175 mm pipe tap provides a connection for a grease fitting and is most often used with a pressure-type grease cup. Additional life can be obtained by using ball bearings with dust seals in the hanger. Shields should be placed on the upstream side of the bearing to protect it from grain pressure and wear.

Inlets and discharge openings

Generally, inlet openings may be cut into the conveyor trough cover wherever needed. Figure 3.20 shows inlet spouts at two locations. Inlet openings should be kept at a sufficient distance from hanger bearings to prevent clogging or choking at

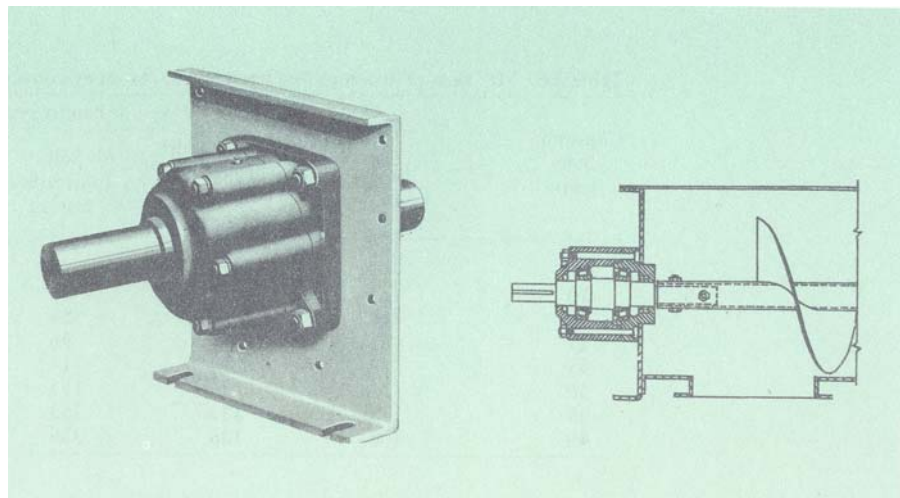

3.23. Outside type thrust bearing for heavy duty service.

3.24. Standard hanger bearing.

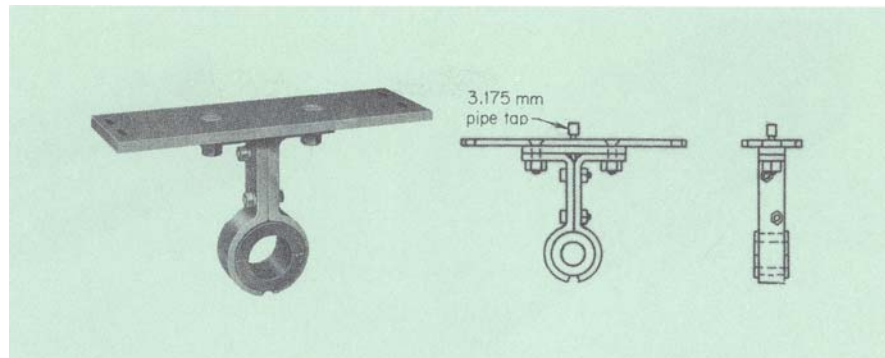

that point. For general use, the inlet opening is square and of the same dimensions as the inside width of the trough. The opening may be flared or an inlet spout may be designed to meet specific needs. Special side opening inlets can also be designed to control the depth of material fed to the trough at that point.

Discharge spouts may be flared or made longer to meet special machinery needs. A standard opening is square and equal to the inside width of the trough. Several types of discharge openings and spouts are illustrated in Figure 3.25.

Troughs and covers

A variety of screw conveyor troughs exist. Two types common to paddy requirements are shown in Figure 3.26: the flanged type with flanged cover installed (A) and the angle flanged type without cover (B). Most troughs for handling paddy are made of high carbon steel or abrasive-resistant alloys to withstand the severe wear.

3.25. Screw conveyor discharge openings and spouts.

Other types of trough covers are illustrated in Figure 3.27. The flat cover is used indoors where waterproofing is not necessary. For most outdoor conveyors where

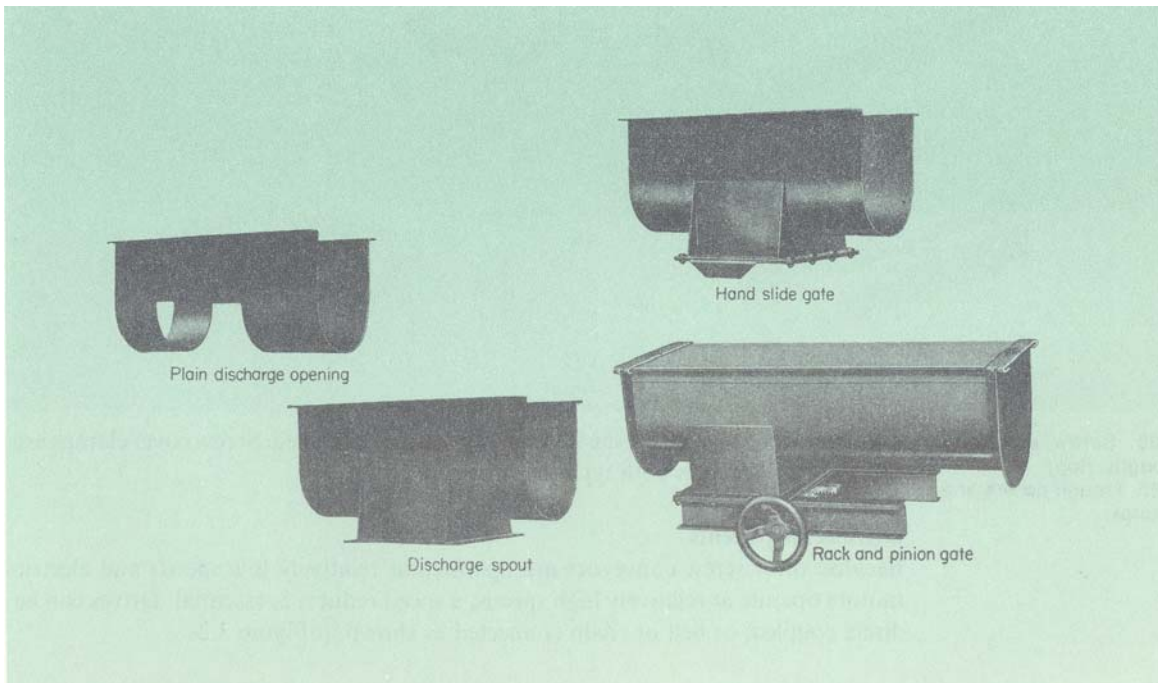

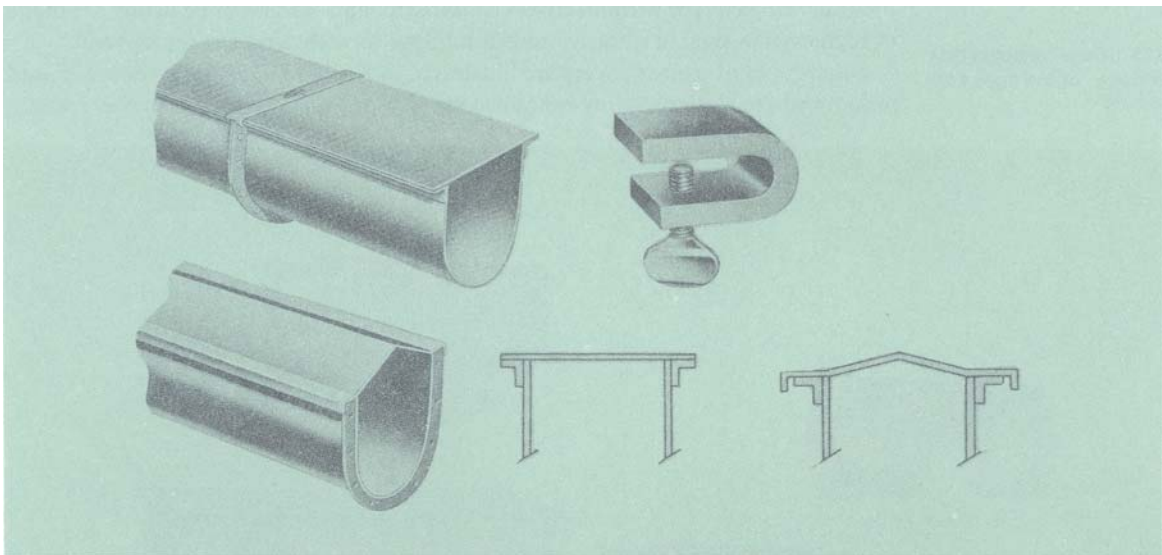
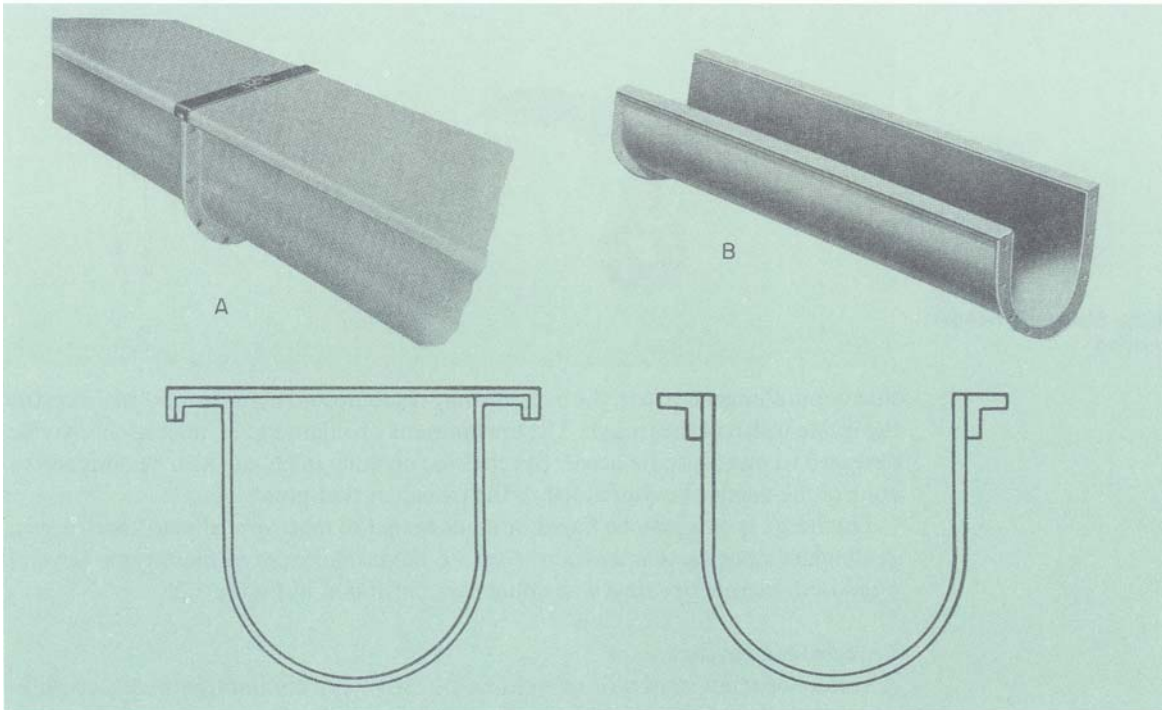

3.26. Screw conveyor troughs. (top)
3.27. Trough covers and clamps.

waterproofing is essential, the flanged-hip roof cover is used. Screw cover clamps are most often used with both types of covers.

Drive arrangements

Because most screw conveyors are operated at relatively low speeds and electric motors operate at relatively high speeds, a speed reducer is essential. Drives can be direct coupled, or belt or chain connected as shown in Figure 3.28.

3.28. Drive arrangements for screw conveyors: *A*, speed reducer mounted on conveyor shaft, motor mounted with V belt connection to slide or top; *B*, self-contained unit with standard speed reducer mounted on the shaft, motor attached and driven by V belt; *C*, gear motor with built-in speed reducer, chain drive to screw shaft,

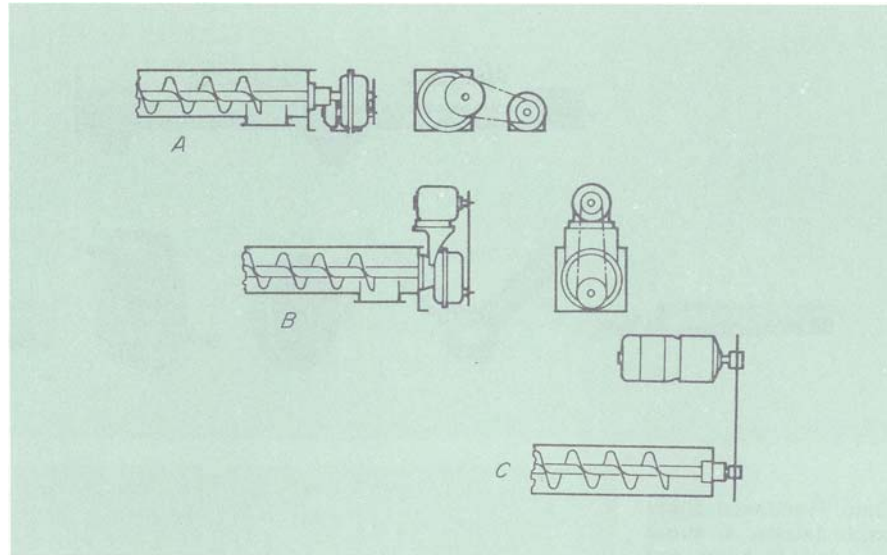

Portable and bin augers

The previous section on screw conveyors provides design data on heavy-duty, continuous-operation screw conveyors, the type which would be used in a paddy storage-processing plant.

In many small storage installations, however, it may be necessary to load and unload bins only a few times per year. This type of operation does not require the type of screw conveyors just described. A number of manufacturers produce special screw conveyors for occasional use. They are generally known as augers. Figure 3.29 shows portable augers *A* used on an incline to move paddy from a tractor-trailer into a dryer and from the dryer into a storage bin, and a horizontal unloading auger *B* under the floor of a storage bin and a vertical auger to move paddy from the storage bin to a truck or into a rice mill. These light-duty augers (fewer operating hours per year) are housed in lightweight closed tubes instead of an open U trough.

3.29. Auger systems: *A*, portable; *B*, installed-in-bin.

Most often they are operated at higher rpm's than those recommended for heavy-duty screw conveyors shown in Figure 3.22. Thus they achieve higher capacities than small-diameter screw conveyors. Generally these augers are less expensive

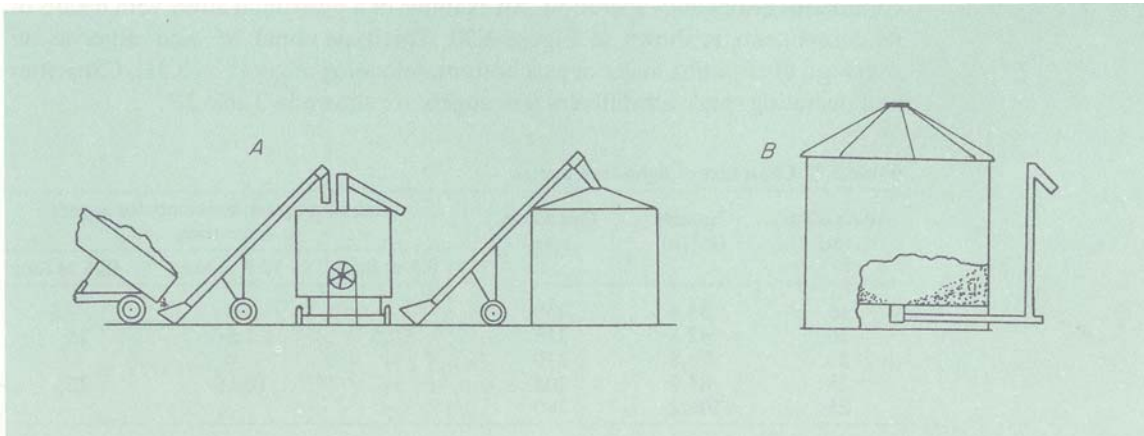

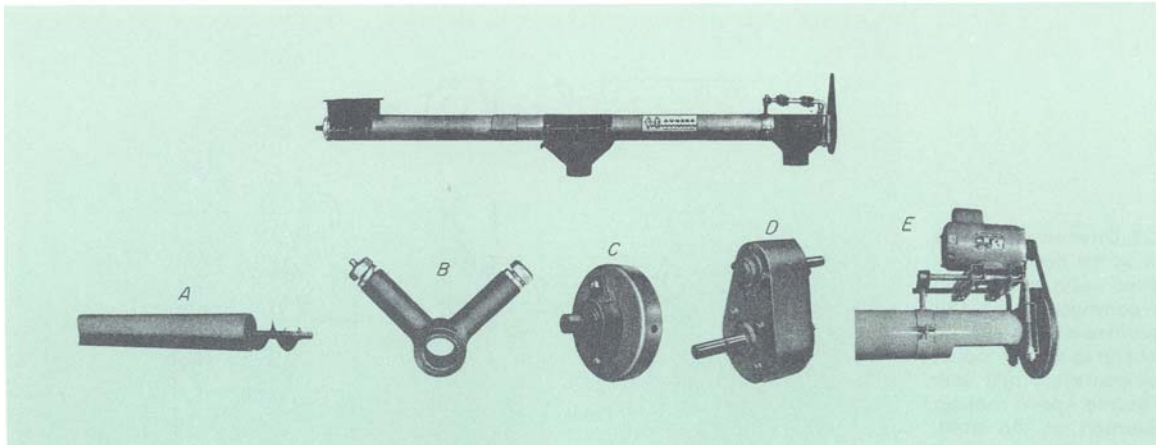

3.30. Horizontal auger with details: A, auger housing, flighting, and stubs; B, intermediate flighting bearings; C, end plate with bearing; D, reduction unit; E, drive unit. (Courtesy of GT Augers)

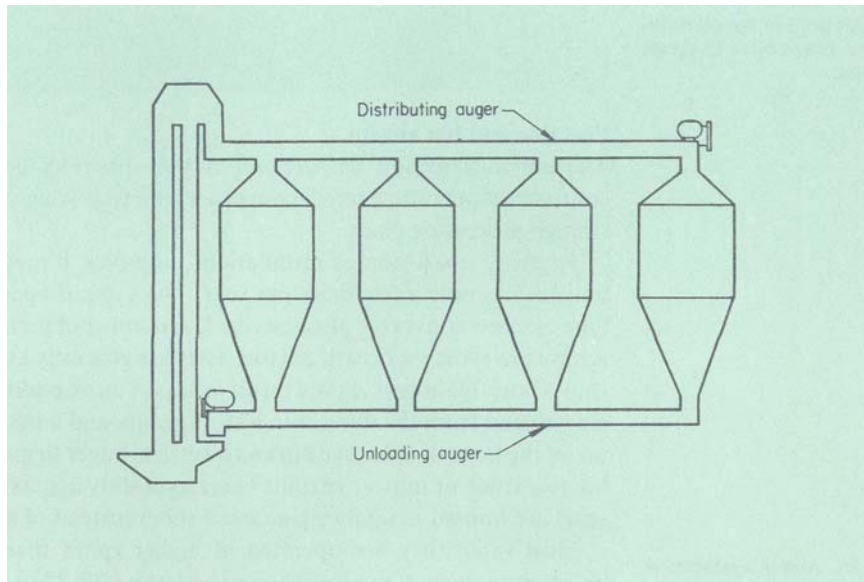

3.31. Distributing and unloading augers.

than heavy-duty types and are more attractive to the operator who does not require continuous heavy-duty operation. An example of a horizontal auger with details of its components is shown in Figure 3.30. This type could be used either as an overhead distributing auger or as a bottom unloading auger (Fig. 3.31). Capacities and operating rpm's for different size augers are shown in Table 3.7.

Table 3.7. Capacities of light-duty augers.

Auger diam (cm)	Capacity (m ³ /h)	Operating rpm	Minimum hp requirements for augers measuring		
			8.5 m long	12.8 m long	18.6 m long
15	35.4	450	3	5	7.5
20	42.5	218	5-7.5	7.5	15
20	70.8	370	—	—	—
25	84.9	205	—	10-15	20
2s	106.2	260	—	—	—

When the auger is operated in a vertical position, the capacity is greatly reduced. For example, when the 15-cm auger in Table 3.7 is operated vertically it has only 20 m³/hour capacity at 620 rpm; the 20-cm auger, only 35.4 m³/hour capacity at 620 rpm. Capacities vary with manufacturers.

Portable augers are designed with the same type trough and screw flight construction as the horizontal augers, but they need extra outside reinforcement because of their long lengths (Fig. 3.32). They are adjustable in height or angle to meet the needs of different size bins or dryers. They may be powered by electric motors or gasoline engines, or be driven by a tractor power takeoff. They are available in 15-cm, 20-cm, or 25-cm diameters. Their capacities vary considerably; for example, a 20-cm auger operating at an angle of 20° may have a capacity of 70 m³/hour. But the same size auger operating at 45° may have a reduced capacity of only 50 m³/hour.

Minimum electrical horsepower requirements could increase by 1/3 with wet paddy if the same capacity in cubic meters per hour is maintained.

Other portable augers are available in smaller diameters, in varying lengths, and for different operational needs.

BELT CONVEYORS

A belt conveyor (Fig. 3.33) is an endless belt operating between two pulleys with its load supported on idlers. It may be flat for moving bags of paddy, or V-shaped for

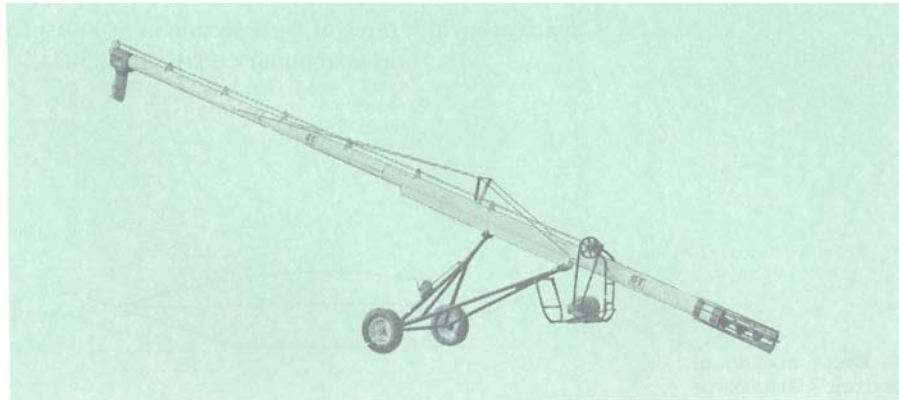

3.32. Portable auger.
(Courtesy of GT Augers)

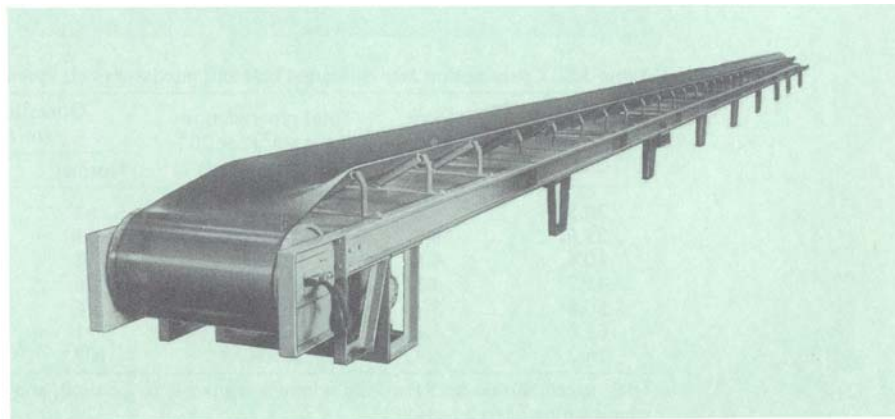

3.33. Typical belt conveyor.

moving bulk paddy. The belt conveyor consists of a belt, drive and end pulleys, idlers, a drive and tension mechanism, and loading and discharge devices. Its carrying capacity depends on the belt width, angle of trough, and belt speed.

Belt conveyors have a high mechanical efficiency because the load is carried on antifriction bearings. Damage to paddy is virtually nil because there is no relative motion between the paddy grains and the belt. Carrying capacity is high because relatively high speeds are possible. Paddy can be conveyed a long distance. A properly designed and maintained belt system has long service life and low operating cost. The initial cost is high for short distance belts and relatively low for long distance belts compared to other types of horizontal conveyors. For these reasons, belt conveyors are widely used to move paddy in many installations. They range from 30-100 cm in width, and may be up to several hundred meters in length.

The load cross section of a troughed belt is shown in Figure 3.34. Cross section areas of loaded belts of various sizes are given in Table 3.8. A trough angle of 20° is best suited for paddy and most other grains. Other common trough angles are 35° and 45°. Paddy forms a surcharge angle (A in Figure 3.34) of 20°. Other common surcharge angles are 5° and 30°.

Belt inclination for paddy and most grains is limited to 15-17°. With inclines larger than this, the grain begins to roll or slide back down the belt thus reducing its effective carrying capacity.

To determine the required belt width, the following formula is used with Table 3.8:

$$\text{Capacity (bu/h)} = (\text{area of cross section in m}^2) \times (\text{speed in m/minute}) \times (60) \times (28.25)$$

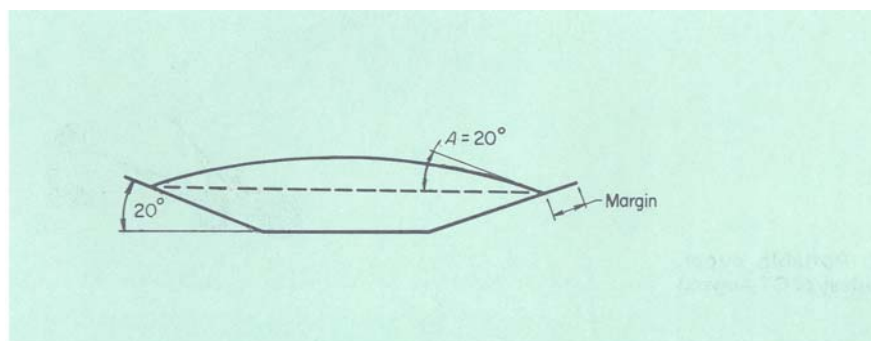

3.34. Cross section of loaded belt: A is surcharge angle.

Table 3.8. Cross-section area of loaded belt and maximum belt speeds.

Belt width (cm)	Clear margin (cm)	Total cross section area (m ²) for 20° surcharge angle	Operation speed ^a (mlmin)	
			Normal	Maximum
30.5	4.1	.0072	61	122
35.6	4.3	.0089	61	122
40.6	4.6	.0122	61	137
45.7	4.8	.0161	76	137
50.8	5.1	.0204	76	152
61.0	5.6	.0308	91	183
16.2	6.4	.0504	107	213

^aBelt speed should be 91 m/min where a tripper is to be used, and 46-76 m/min where a plow is to be used.

Example: Determine belt width and speed to convey 1,200 bu of paddy/ hour. Using the cross sections from Table 3.8, a 35.6 cm belt traveling at 81 m/ minute would give:

$$.0089 \times 81 \times 60 \times 28.25 = 1,221 \text{ bu/ hour}$$

and a 30.5 cm belt traveling at 99 m/minute would give:

$$.0072 \times 99 \times 60 \times 28.25 = 1,208 \text{ bu/hour.}$$

In this example the 35.6-cm-wide belt at 81 m/ minute is adequate, unless a tripper is to be used (minimum of 91 m/minute for tripper use). Then the 30.5-cm belt at 99 m/minute should be used.

The top idler spacing should be 1.5 m for belts up to 0.5 m wide and 1.4 m for belts 0.6-0.9 m wide. The return idler spacing for belts up to 0.9 m wide should not exceed 3 m. After belt speed in meters per minute has been determined, then rpm of the head pulley shaft can be calculated with Table 3.9 as a guide.

The horsepower required for moving paddy by belt conveyor may be calculated by the following formulas that are based on the lift, friction resistance of the belt and the pulleys, and tripping device.

$$\text{hp 1} = \frac{\text{Belt speed}}{0.3048} \times \frac{A + B (3.281 L)}{100}$$

$$\text{hp 2} = (\text{t/ hour}) \times \frac{0.48 + .01 L}{100}$$

$$\text{hp 3} = \frac{\text{lift}}{0.3048} \times 1.015 \times \frac{\text{t/ hour}}{1000}$$

Where L = belt length in meters, belt speed is in meters per minute, lift in meters, and A and B are constants from Table 3.10.

Table 3.9. Revolutions per minute (rpm) of pulley shaft for various belt speeds and pulley diameters.

Belt speed (m/min)	Pulley shaft rpm when pulley diam is				
	50 m	60 cm	76 cm	90 cm	110 cm
30	20	16	14	11	9
46	28	24	20	16	14
61	38	32	25	22	18
16	48	41	32	27	24
91	55	48	38	32	27
107	65	55	45	38	32
122	75	65	51	43	36

Table 3.10. Constants for determining horsepower for belt conveyors.

Conveyor belt width (cm)	Constants		Additional hp for tripper
	A	B	
36	0.20	.00140	0.70
41	0.25	.00140	0.85
46	0.30	.00162	1.00
50	0.30	.00187	1.40
60	0.36	.00224	1.70
76	0.48	.00298	2.50

The total horsepower required is the sum of the powers calculated from the three equations, plus that required for the tripper from Table 3.10.

For example: A belt carrying 18 t/hour, 41 cm wide, traveling at 110 m/minute for a distance of 90 m, with a 3-m lift:

$$\text{hp } 1 = \frac{110}{0.3048} \times \frac{0.25 + (.0014) (3.281) (90)}{100} = 2.39$$

$$\text{hp } 2 = 18 \times \frac{.048 + (.10) (90)}{100} = 0.25$$

$$\text{hp } 3 = \frac{3}{0.3048} \times 1.015 \times \frac{18}{1000} = 0.18$$

Plus for the tripper (from Table 3.10) = 0.70

Total hp = 3.52

3.35. Cross section of belt conveyor: A, drive pulley; B, idler; C, tripper; D, feed hopper; E, adjustable belt-tensioning pulley. (below) 3.36. Belt loading arrangement showing metal or wood frame with rubber skirt and extra set of idlers. (bottom)

A cross section of a belt conveyor with its major parts is shown in Figure 3.35. Note that the feed hopper is installed near the upper end of the belt. It has guides on the side to prevent the paddy from splashing off as it feeds onto the belt. These guides may be metal or wood, 60-90 cm long, installed slightly above the belt surface to prevent wear on the belt. Details are shown in Figure 3.36.

In Figure 3.35, the belt moves along the top idlers, which are spaced close together to carry the load. The tail pulley is adjustable to maintain the correct belt tension. Paddy is discharged by a belt tripper, which is movable along the length of the belt and incorporates a two-way discharge valve so that the paddy can be discharged on

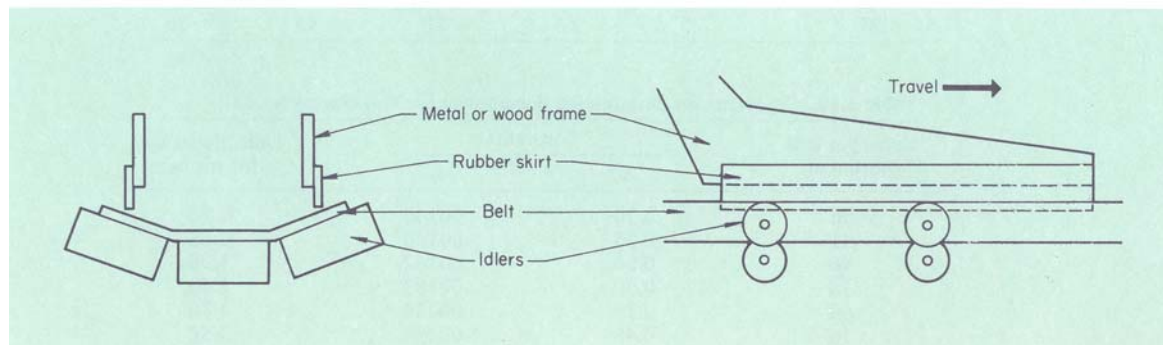
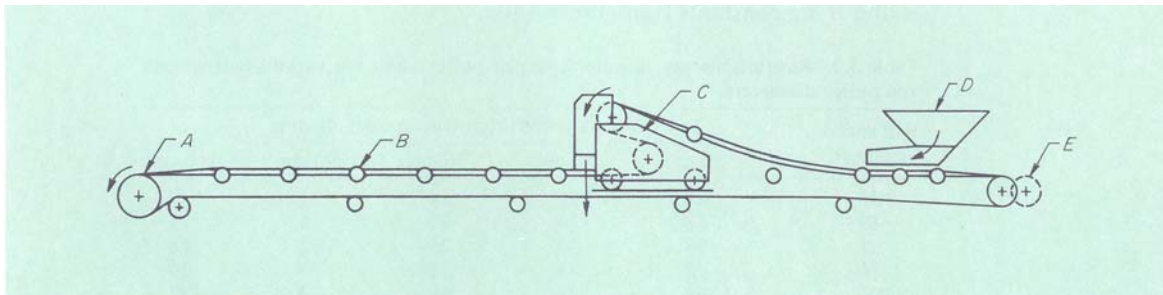

either side of the belt.

A standard set of top idlers is shown in Figure 3.37. The side idlers are positioned at the 20° angle required for paddy. They are designed for periodic lubrication. The center roller has an extended grease pipe on the side for easy access. Figure 3.38 shows dimensions of standard idlers. Tapered roller bearings with outer dust and water seals are most commonly used.

Self-aligning idlers (Fig. 3.39) are used for training troughed belts. They automatically correct belt misalignment due to off-center loading, uneven belt stretch, misalignment of supports, or other common field working conditions. A self-aligning idler replaces a standard idler every 15-30 m.

Self-aligning idlers should use the same rollers and bearings as the standard idlers. Self-aligning camber idlers (Fig. 3.40) installed on the return belt help train the loaded belt. The idlers are often overlooked in conveyor belt designs.

Paddy generally is discharged from the belt conveyor over the end pulley or at any point along the conveyor by a scraper plow or a throw-off carriage known as a tripper. The discharge over the end pulley of the belt is simple and does not require any special mechanism. A common use of this type discharge is from a belt conveyor into the boot of a bucket elevator.

The discharge scraper plow is a board placed at an angle (usually 30 to 49°) to the longitudinal axis of the belt and fastened on a frame that can be raised or lowered onto the belt as required. In the operating position, the plow rests on the belt, pressing against it with a rubber strip fastened to the board. The plow can be used to discharge paddy from either side of the belt. As the paddy grains traveling on the belt come in contact with the plow, they are deflected to the side of the belt and discharged. The discharge plow is not commonly used with paddy because small paddy grains often slide under the plow and are not discharged at the desired

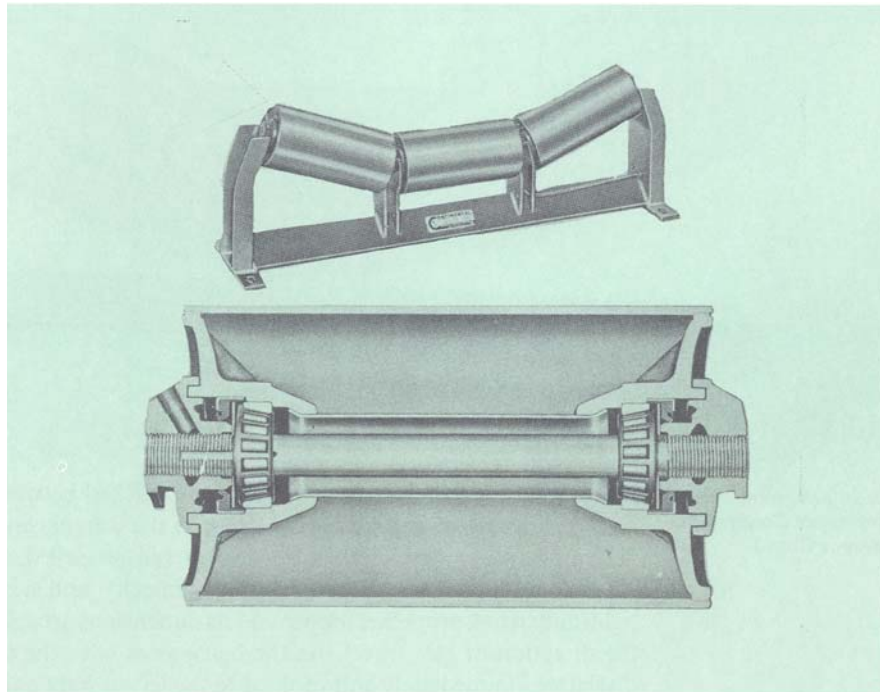

3.37. Standard idlers for belt conveyors. (Courtesy of Continental Conveyor Corp.)

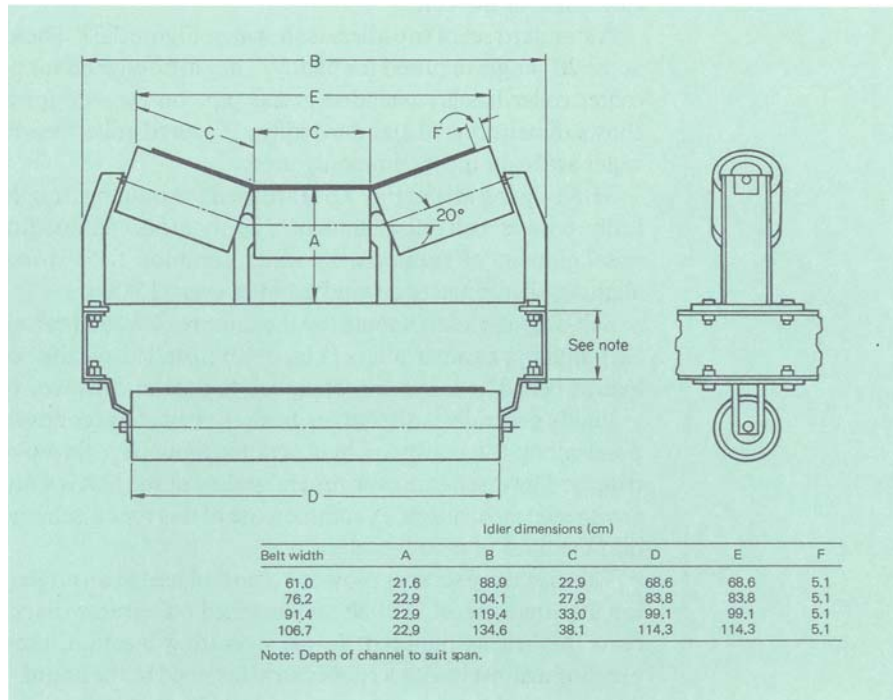

3.38. Dimensions of standard idlers using 12.7 cm center rollers.

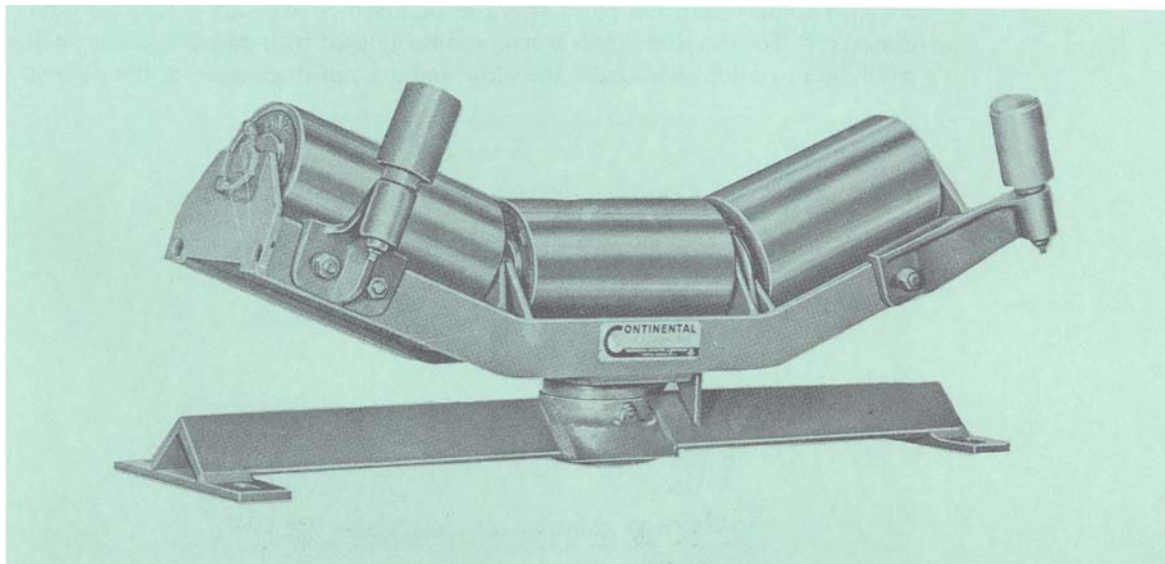

3.39. Self-aligning idlers. (Courtesy of Continental Conveyor Corp.)

location. Also, some grains are crushed or cracked between the plow and the belt surface. If the plow is adjusted too close to the belt, excess belt wear results.

Trippers are available as hand-propelled, self-propelled, or automatic. The choice depends on the particular installation, its capacity, and system operation. A simple light-duty hand-propelled tripper and its dimensions are shown in Figure 3.41. Note the direction of belt travel. As the belt passes over the top pulley, the paddy is discharged immediately and spouted to the left or right as desired. The hand crank

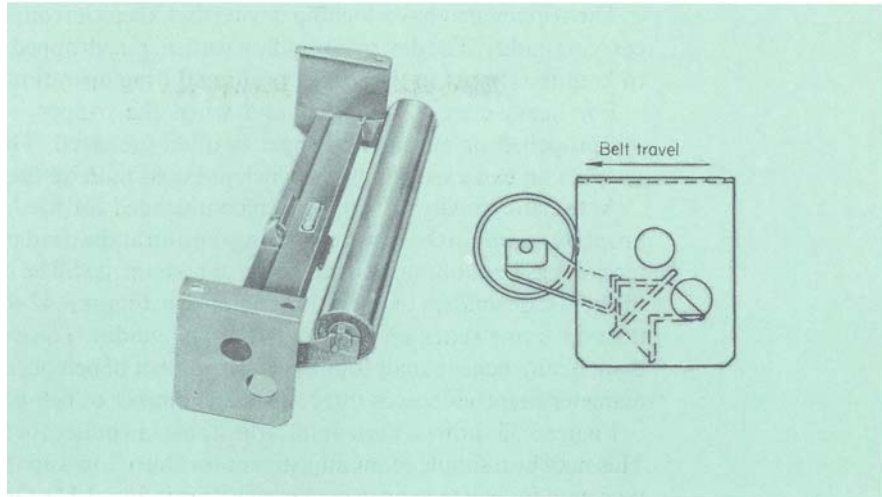

3.40. Self-aligning camber return idlers. (Courtesy of Continental Conveyor Corp.)

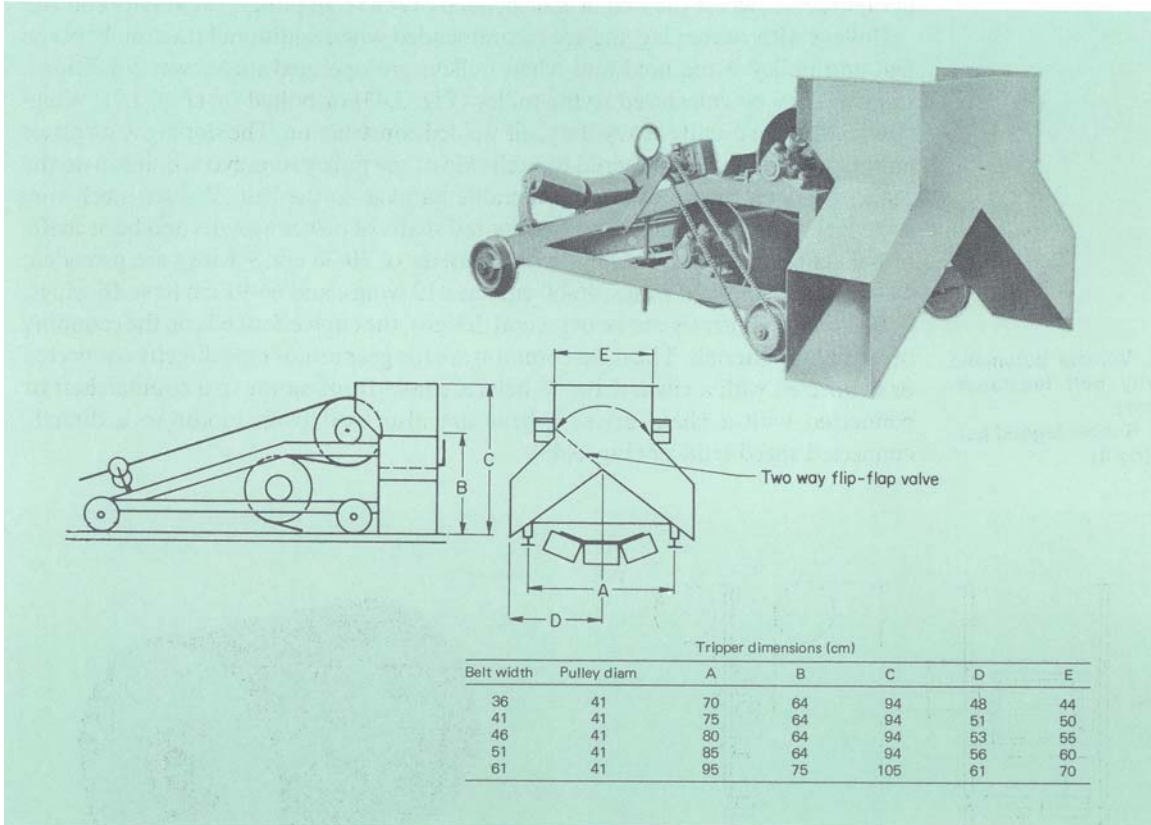

3.41. Schematic and dimensions of light-duty, hand-propelled tripper for various belt widths. (Courtesy of Continental Conveyor Corp.)

with chain drive on the side permits the operator to move the tripper in either direction along the belt. A tripper normally is installed on two I-beams running the length of the belt conveyor and becomes part of the conveyor's frame.

Note the two-way flip-flop valve in Figure 3.41, which permits the grain to be discharged on either side of the belt as desired. This is a simple arrangement used in

most installations.

The tripper also has a locking device that keeps it from moving when the belt is carrying paddy. The device is usually a vertical pin, dropped through a fixed opening to keep the tripper in the locked position during operation.

For heavy-duty installations and when the tripper is to be moved often, a self-propelled or automatic tripper is often preferred. The self-propelled tripper involves an extra set of pulleys which are used to drive the tripper.

Automatic gravity take-ups are recommended for the longer belt conveyors to properly maintain the required driving tension at the head pulley. Where the proper tension has been obtained by this type of take-up, it will be maintained for the life of the belt, independent of operating conditions. Figure 3.42 shows a vertical unit. The take-up frame slides up and down on pipe guides. The minimum take-up pulley diameter in inches equals four times the number of belt plies. Minimum bend pulley diameter in inches equals three times the number of belt plies.

Figure 3.35 shows a horizontal, adjustable tail pulley for belt tension adjustment. This may be a simple screw adjustment for short, low-capacity conveyors (the same type used for belt tension in bucket elevators in Fig. 3.11). Or it may be similar to that in Figure 3.42, where the weight is suspended over a set of pulleys for gravity control.

Pulleys with rubber lagging are recommended when additional traction between belt and pulley is required and when pulleys are operated under wet conditions. Lagging may be vulcanized to the pulley (Fig. 3.43) or bolted on (Fig. 3.9). Wing-type pulleys are usually heavy-duty, all-welded construction. The sloping wing plates automatically shed the material to each side of the pulley to prevent buildup on the pulley face, which can cause considerable damage to the belt. Welded steel wing pulleys (Fig. 3.44) are recommended for tail shafts of belt conveyors and boot shafts of bucket elevators. For pulleys with diameter of 30-34 cm, 9 wings are provided; 40-cm pulleys have 10 wings; 44-60 cm have 12 wings; and 66-91 cm have 16 wings.

Belt conveyor drives can be of several designs; the choice depends on the economy of available materials. The most common are the gear motor type directly connected or connected with a chain drive. V-belts are used from motor to a countershaft or connected with a chain drive. V-belts are also used from motor to a directly connected speed reducer (Fig. 3.45).

3.42. Vertical automatic gravity belt tensioner. (below)

3.43. Rubber lagged pulley. (right)

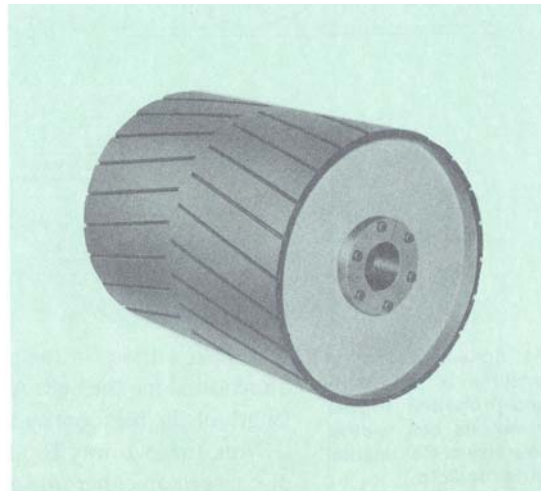
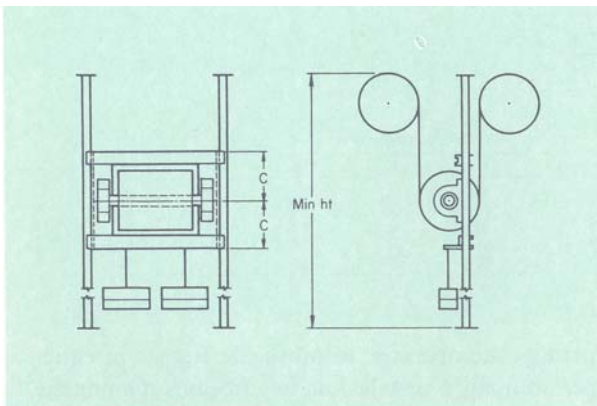

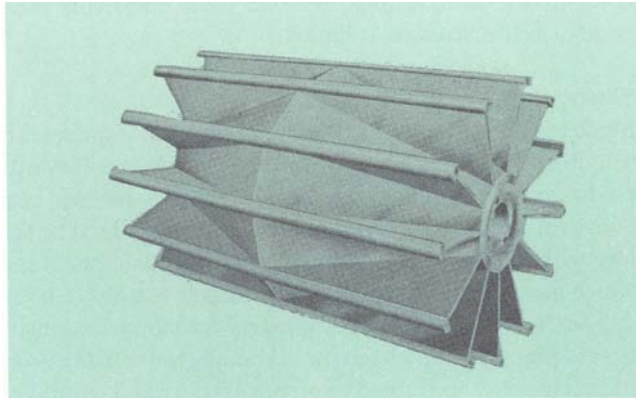

3.44. Wing-type pulley.

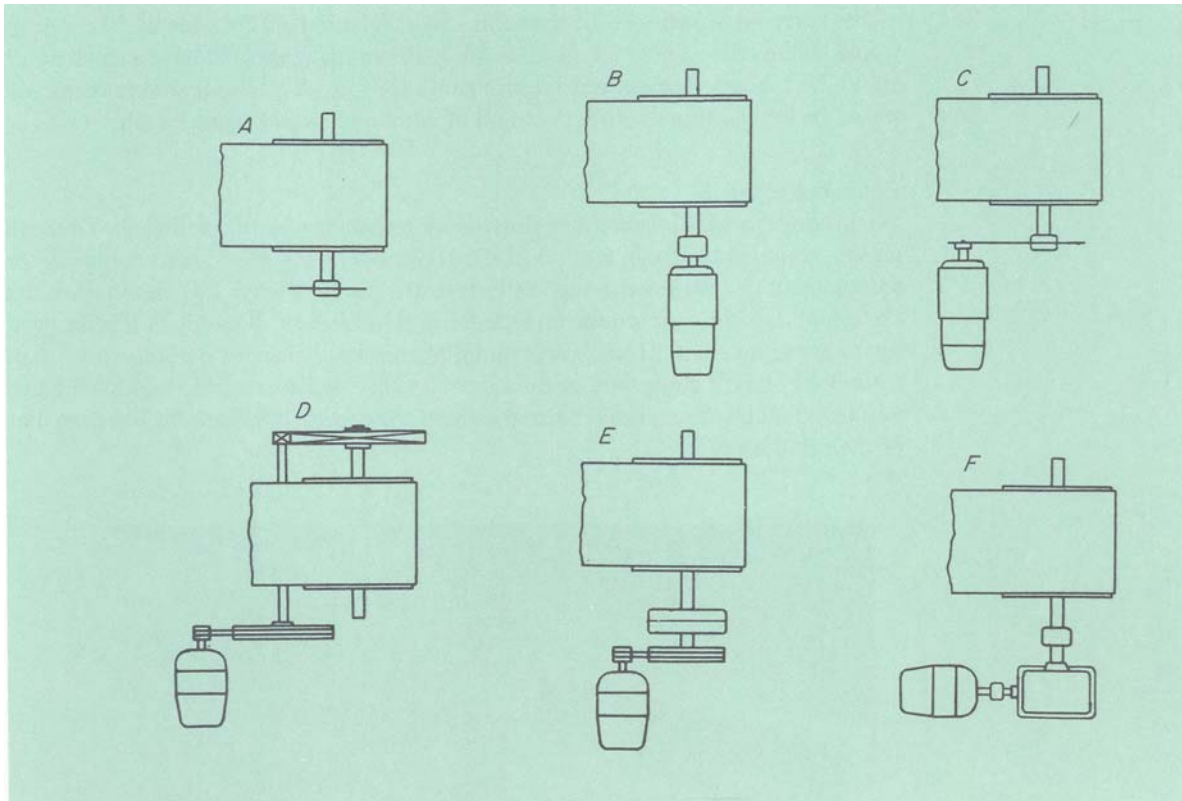

3.45. Belt conveyor drives
A, simple chain drive from power source; **B**, direct gear motor; **C**, gear motor with chain reduction to shaft; **D**, V-belt drive to countershaft with gear to head shaft; **E**, V-belt to speed reducer (direct connected); **F**, motor to speed reducer coupled to head shaft.

OTHER PADDY CONVEYORS

Several other type conveyors are occasionally used to move paddy. They include shaker (vibrating), chain (drag), and pneumatic conveyors. The major disadvantage of the shaker conveyor is its limited capacity. The major disadvantage of chain and pneumatic conveyors is their short life due to the extreme abrasiveness of paddy

compared to other grains. Because these conveyors are seldom used for moving paddy, their discussion is limited.

Shaker conveyor

Shaker (also called vibrating, oscillating, or grasshopper) conveyors move paddy in a uniform, continuous flow by the upward and forward oscillating motion of a continuous trough that is mounted on sturdy inclined reactor legs (Fig. 3.46). The conveyor consists of a steel or wood trough mounted on flat spring, resilient support legs with a positive action drive. The drive consists of a motor turning a shaft on which an eccentric provides the oscillating action to the trough.

The shaker conveyor is designed for horizontal conveying. It is particularly suited for moving wet paddy from the parboiling tanks to the dryer. In this case, the bottom of the trough is perforated to permit excess water from the parboiled paddy to drain before reaching the elevator leg.

The carrying capacity of the shaker is small. A trough 30 cm wide by 10 cm deep would be limited to about 5 t/ hour. A 46- × 10-cm trough would have a capacity of about 7.5 t/ hour. Horsepower requirements are low. A 5-t/ hour shaker conveyor would be limited to a maximum length of 21 m and would require 1 hp.

Chain conveyor

Chain conveyors are inexpensive, slow, noisy, and mechanically inefficient. To move paddy, scrapers or drags used with the chain operating in a closed container or trough incur excessive wear due to the abrasive paddy. Figure 3.47 shows the cross section of the conveyor trough and the normal movement of paddy as it is dragged by the conveyor chain. Horsepower requirements for chain conveyors are more than for belt or shaker conveyors of the same capacity. Because of the highly abrasive nature of paddy, the expected life of the chain conveyor is considerably less than that of the belt conveyor.

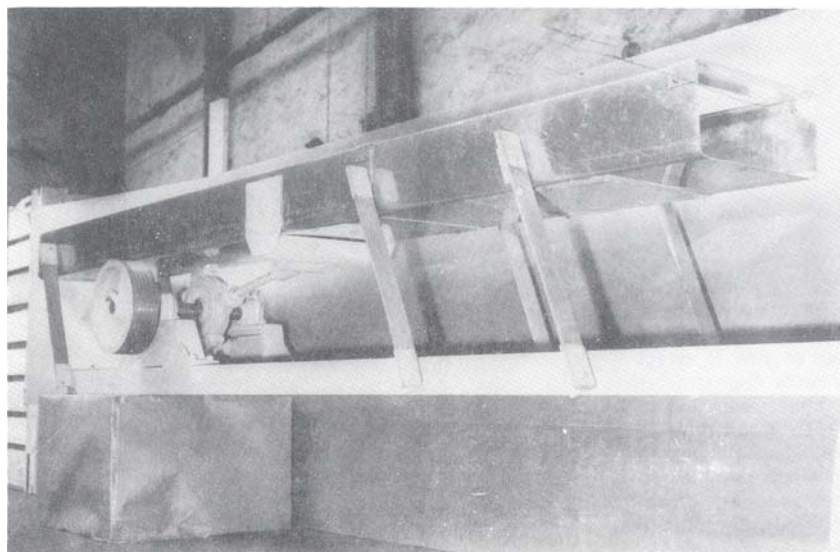

3.46. Shaker or vibrating-type conveyor showing spring mounting and power drive.

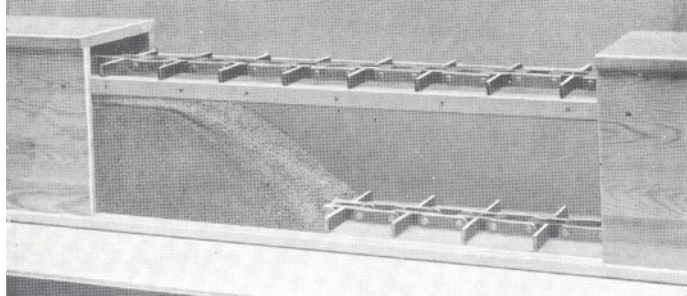

3.47. Cross section of chain-drag conveyor.

Pneumatic conveyor

Pneumatic conveyors move material in a closed-duct system by a high-velocity air stream. The system uses a material feeder or collector, an air blower, ducts, and a cyclone for collection or discharge. Figure 3.48 illustrates a common use of the pneumatic system — unloading ships or railcars and conveying the grain into a storage or another handling system.

The power requirements for a pneumatic conveyor are high. A larger problem is the excessive wear on the equipment caused by the highly abrasive paddy. Therefore, the pneumatic system is seldom used for moving paddy.

The pneumatic conveying system is most useful in handling less dense paddy husk and other by-products such as bran and fine brokens. It is hard to beat for handling husk and bran. Wear is minimized by the proper duct design, velocity considerations (not too fast, not too slow), and matching the system to the requirements.

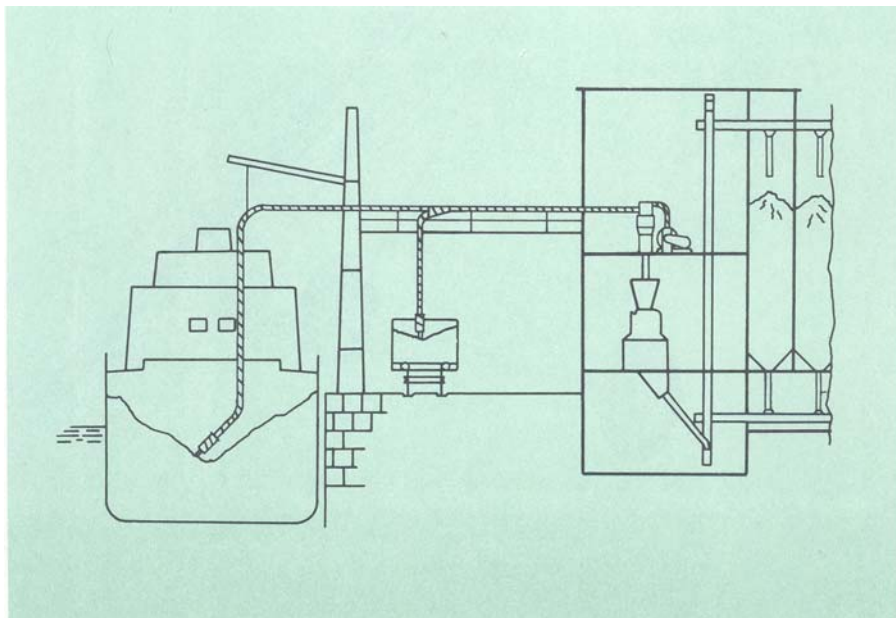

3.48. Typical pneumatic conveying system.

Portable conveyor

Another type of portable loader or inclined elevator is shown in Figure 3.49. It is chain driven with paddles attached to the chain, which operates in a metal trough. It is used to move bulk paddy and gunny bags of paddy to higher sites. It may be 9-21 m long and is most useful as a supplement to labor in stacking bags of paddy in large storage facilities.

GRAIN VALVES AND SPOUTING

In most paddy-handling installations, grain valves and grain spouting are used with bucket elevators and screw conveyors. Paddy moves by gravity through these grain valves and spouting. Because the angle of repose for paddy is 36-37° all spouting is installed at a minimum angle of 45°. Discharge valves are designed for this minimum angle and as long as that angle is maintained, paddy should flow freely.

3.49. Portable conveyor.
(Courtesy of Cardinal
Division, LML Corp.)



Most spouting is straight steel pipe with flanged or unflanged ends, depending on installation requirements. Spouting 15 cm in diameter is usually available in 14 or 12 ga; 20 cm is available in 10, 12, or 14 ga. Standard 22.5°, 45°, and 60° elbows are available. Adjustable elbows that make installation much easier are also available.

For capacities of 1,500 bu/hour (30 t/hour) or less, 15-cm spouting and valves are adequate. For capacities from 1,500 to 3,000 bu/hour (60 t), 20-cm spouting is used. From 3,000 bu to 4,500 bu/hour (90 t), 25-cm spouting is used.

The impact of falling paddy is extremely abrasive and rapidly wears out spouting and elbows. A grain trap such as that shown in Figure 3.50 is used where falling paddy would cause excessive wear on the elbow. The abrasive action of the paddy is absorbed by the trapped grain and saves wear on the elbow.

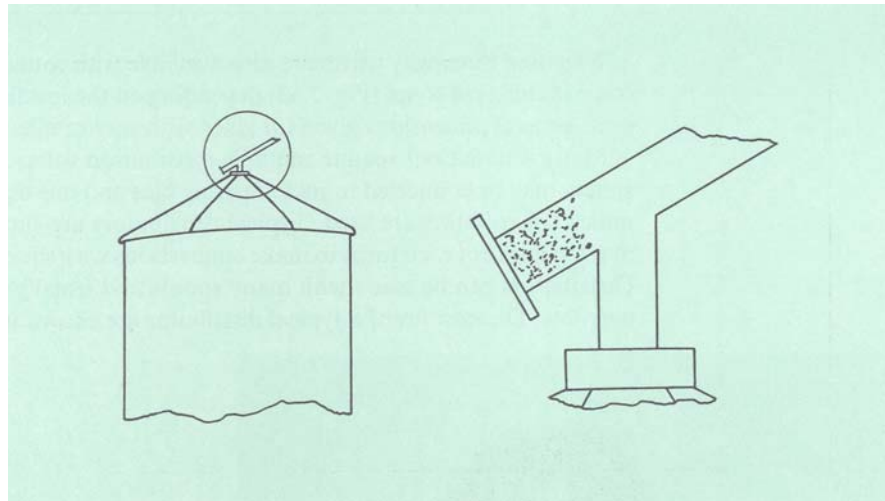

3.50. Grain trap used to reduce wear on elbows.

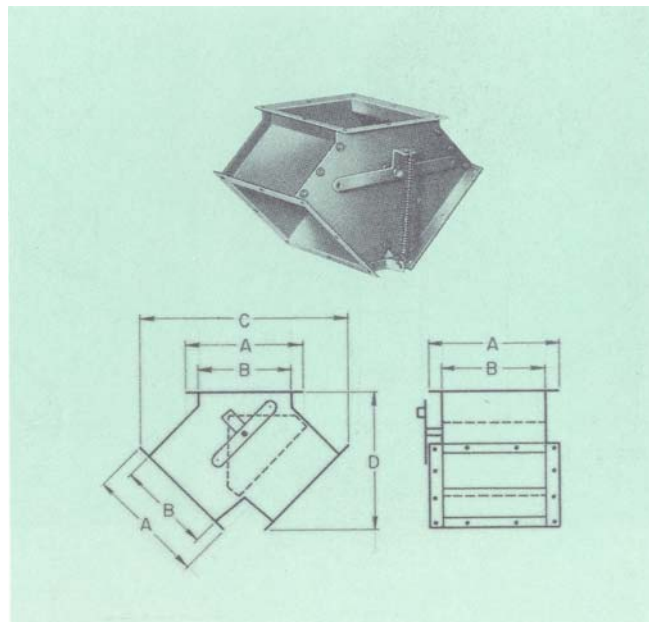

3.51. Two-way valve with bucket-type gate.

Two- and three-way grain valves are the most common. They operate on either the bucket-type gate as shown in Figure 3.51 or the flop gate as shown in Figure 3.52. Spring tension enables the valve to open in either direction. The internal gate is fabricated of abrasive-resistant steel. The valve may be operated by chain or cable. Normal dimensions for these valves are given below:

		Valve dimensions (cm)				
		A	B	C	D	E
15-cm	spouting	21.6	15.2	38.1	31.7	50.8
20-cm	spouting	26.7	20.3	45.7	36.8	57.2
25-cm	spouting	31.8	25.4	54.6	40.6	61.0

Two- and three-way valves are also available with round inlets and outlets. They come in different styles (Fig. 3.53) depending on the installation requirements. The same general dimensions given for gates with square inlets and outlets apply.

Many installations require multiple distribution valves. An elevator in a drying system may be connected to six tempering bins and one dryer. For more than three outlets, distributors are used. Typical distributors are shown in Figure 3.54. Note that the inside of each turns to make connections with the desired opening or spout. Distributors can be made with many spouts and usually contain one spout as an overflow. Dimensions of a typical distributor are shown in Figure 3.55.

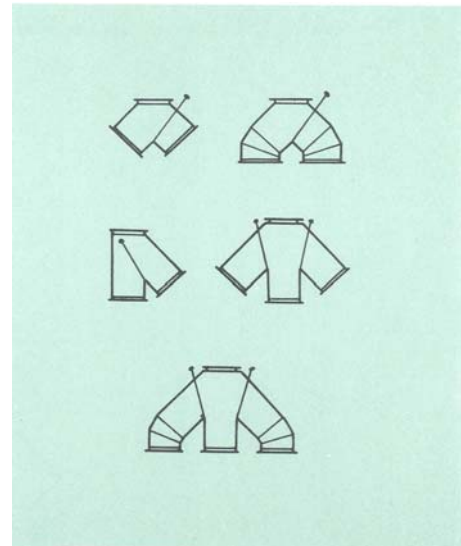
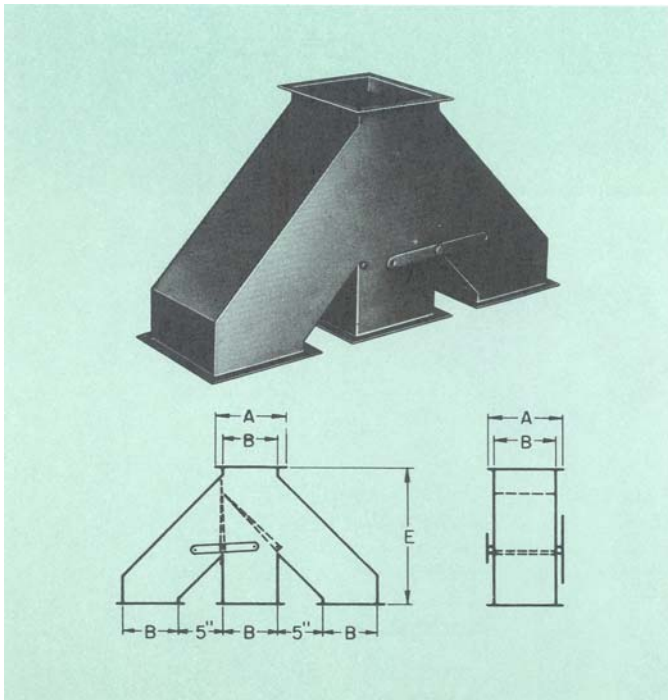

3.52 Three-way valve with flop gate. (top)
3.53. Two-way and three-way valve arrangements. (right)

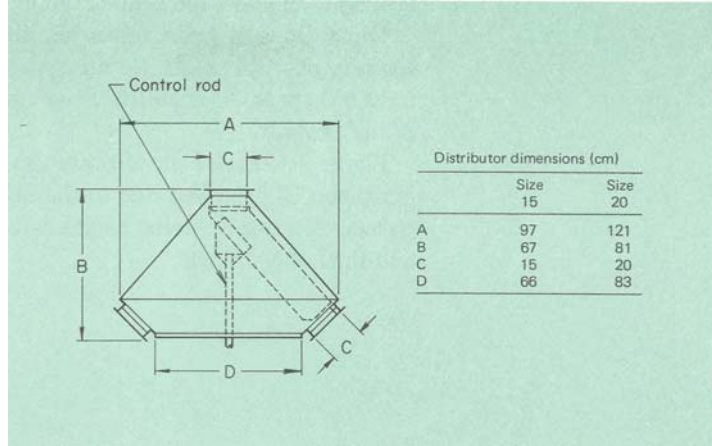
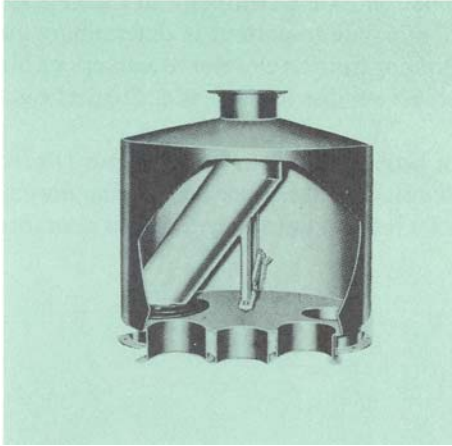

3.54. Five-way distributor.

(top)

3.55. Schematic and dimensions for two sizes of distributors. (upper right)

3.56. Schematic of elevator. *A*, total height; *B*, head clearance; *C*, normally quoted effective elevating height; *D*, head loss due to distributor or valves; *E*, effective elevating height with distributor; *F*, hopper height up leg feed; *G*, hopper height down leg feed. (lower right)

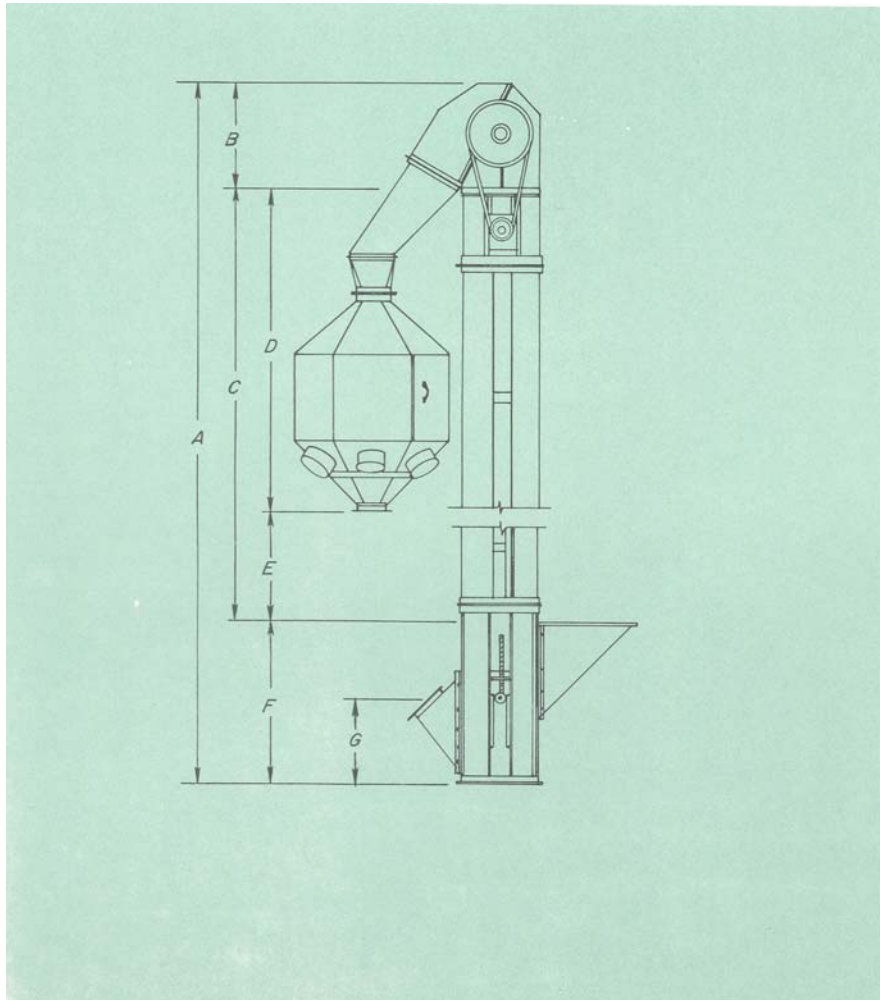

The distributor is controlled by either cable or steel rod from an indicator at ground level. Note the control rod at the bottom of the distributor in Figure 3.55.

Dimensions of grain valves and distributors are important in determining the required elevator height. Because grain spouting from an elevator to a dryer or a bin must be kept at 45° angle, the height of the valve or distributor is added to the height of the elevator.

Figure 3.56 shows the effective elevator height as the total height minus 1) head clearance, 2) head loss due to the distributor, and 3) hopper height. The normal quoted effective elevating height is the total height minus only the head clearance and the hopper height.