

Spur gears, bevel gears worm gear pairs



Description:

Our standard, "toothing to customer requirements" no "catalog toothed gears".

Special features:

- Spur gears, straight and helical geared up to module 2,5
- Bevel gears, straight and special geared up to module 2
- Worm and worm wheels as gear pairs up to module 2,5
- Tooth belt pulleys in different profiles

Application areas of our tothing parts:

- Medical technology
- Automotive engineering
- Railed vehicles
- Buses
- Drive units in clean rooms (chip production/solar cells)
- Sun protection
- Sport + leisure
- Modelbuilding
- Rehabilitation, health care
- Food industry

Spur gears, bevel gears, worm gear pairs

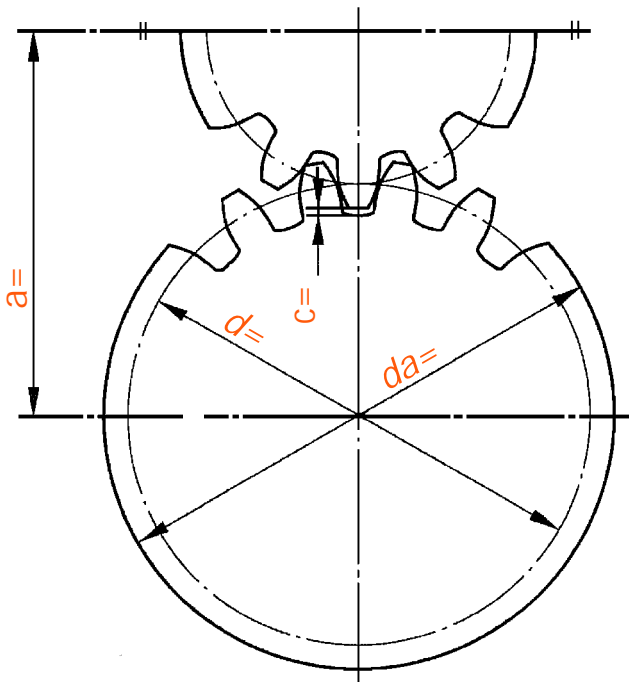

Spur gears with straight gearing

Gear dimensions

Module

$$m = \frac{p}{\pi} = \frac{d}{z}$$

Number of teeth

$$z = \frac{d}{m} = \frac{da - 2 \cdot m}{m}$$

Bottom clearance

$$c = 0,1 \cdot m \text{ bis } 0,3 \cdot m \text{ up to often } c = 0,167 \cdot m$$

Reference diameter

$$d = m \cdot z = \frac{z \cdot p}{\pi}$$

Tip diameter

$$da = d + 2 \cdot m = m(z + 2)$$

- m = Module
- d = Reference diameter
- da = Tip diameter
- z = Number of teeth
- c = Bottom clearance
- a = Centre distance

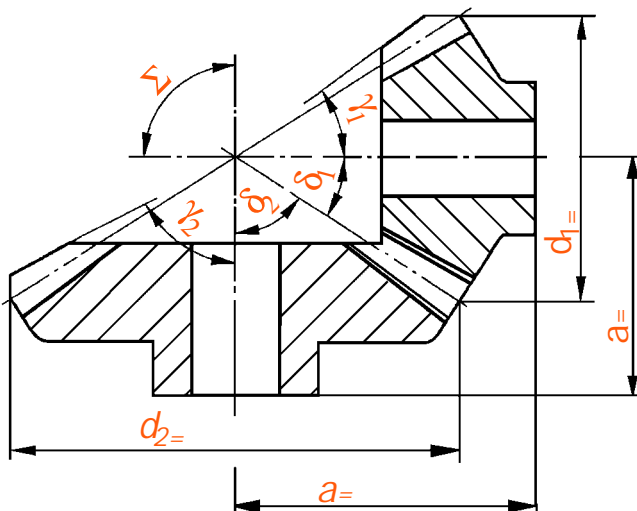

Bevel gears with straight gearing

Reference diameter

driving gear

$$d1 = m \cdot z1$$

driven gear

$$d2 = m \cdot z1$$

Taper angle

$$\tan \gamma 1 = \frac{z1 + 2 \cdot \cos \delta 1}{z1 - 2 \cdot \sin \delta 1}$$

$$\tan \gamma 1 = \frac{z2 + 2 \cdot \cos \delta 2}{z1 - 2 \cdot \sin \delta 2}$$

Reference angle

$$\tan \delta 1 = \frac{d1}{d2} = \frac{z1}{z2} = \frac{1}{i}$$

$$\tan \delta 1 = \frac{d2}{d1} = \frac{z2}{z1} = i$$

Shaft angle

$$\Sigma = \delta 1 + \delta 2$$

Bottom clearance, tooth height, addendum etc. see spur gears

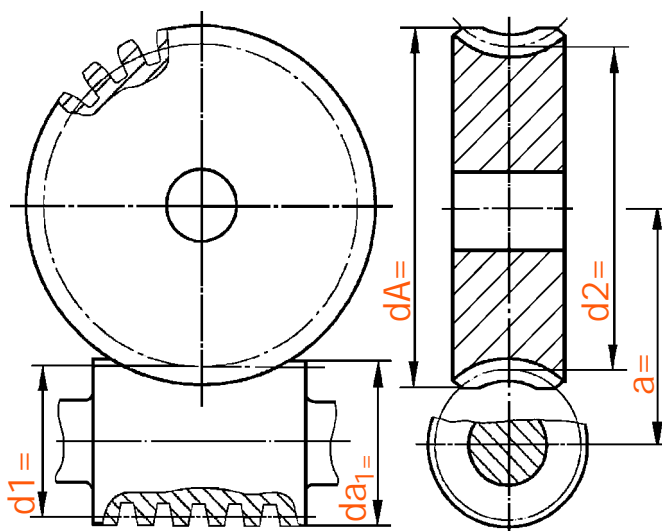

Worm gear

Reference diameter

worm

$$d1 = \text{nominal size}$$

worm wheel

$$d2 = m \cdot z2$$

Tip diameter

$$da1 = d1 + 2 \cdot m$$

Outer diameter

$$dA \sim da2 + m$$

Centre distance

$$a = \frac{d1 + d2}{2}$$

Bottom clearance, tooth height, addendum etc. see spur gears