

Cubic Screw Jack Family

MULI®, JUMBO®



Lifting >> Tilting >> Lowering >> Feeding



MULI®, JUMBO®



RHINO



MARYLAND METRICS offers: Screw Jacks

Superior performance. Superior design.

MARYLAND METRICS

phones: (800) 638-1830 (410) 358-3130

faxes: (800) 872-9329 (410) 358-3142

E-mail: sales@mdmetric.com URL: <http://mdmetric.com>

P.O.Box 261 Owings Mills, MD21117USA
6119 Oakleaf Avenue Baltimore, MD21215USA

[click for Trapezoidal Rod/Screwjacks page index](#)

>> Excellence by design

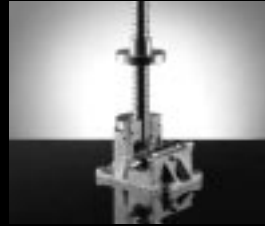

Available from: **MARYLAND METRICS**

These products are manufactured by the world leaders in the design and manufacture of mechanical linear actuation and power transmission equipment. With modern facilities in Europe and North America, they are able to supply customers on a worldwide scale. Advanced CNC machining equipment and fully computerized systems for product design and manufacturing maximize efficiency and product reliability while minimizing production lead-time. All of these products can be customized for application in your system. In-house research, development, design and production are backed by the factories Total Quality Management guarantee to ensure that these products and accessories meet the highest possible standards.

These screw jacks are rated for some of the harshest conditions, including nuclear applications, and offer load capacities from 1,100 lbs (5 kN) to 110 tons (1,000 kN).

These innovative cubic screw jack designs are modular in configuration and offer flexible mounting.

Our supplier is one of the only manufacturers to offer imperial and metric screw jacks in North America and Europe.

Maryland Metrics offers a comprehensive range of lead screws, ball screws, planetary roller screws, precision gearboxes, linear actuators, screw jacks and electro-mechanical products.

No matter what your problem may be, the factories sales and applications engineers, certified technicians and master assemblers are available to assist in integrating these products into your system. All of our engineers have technical degrees and are experts in our industry.

Maryland Metrics in conjunction with the manufacturer offers expertise in engineering complete systems packages.

>>Just a few of the working applications for our screw jacks



Auto manufacturing



Food processing



Paper production



Carpet shearing

Auto manufacturing

Application: Moving cut sheet metal from horizontal to vertical position on a bundle turnover machine at a major car manufacturer's metal stamping plant.

Product: Translating screw jacks linked by drive shafts and couplings.

Food processing

Application: Adjustment of gauge rolls for controlling dough sheet thickness on a biscuit making machine.

Product: Two translating screw jacks per machine.

Paper production

Application: Adjustment on the head box of a paper machine. Two jacks are mounted horizontally and two vertically to move the slice body, which controls the thickness of the finished paper product.

Product: Translating and rotating screw jacks with special stainless steel screws, wormshafts and bottom pipes and fitted with an anti-backlash feature.

Carpet shearing

Application: Blade adjustment on a multi-head carpet-tip shearing machine to produce varying carpet pile thicknesses.

Product: Two translating screw jacks per shearing head, with keyed screws and fitted with protective bellows.



Power station operations



Waste recycling



Metal processing



Glass packaging



Foam production

Power station operations

Application: Raising and lowering dampers in power station flues to enable maintenance to be carried out without disrupting power generation.

Product: Two rotating jacks with 4 meter (13 feet) screws, cross linked with a drive shaft and couplings.

Waste recycling

Application: Pre-feeding and stacking in a machine which converts waste agricultural product into fiber board.

Product: Eight rotating ball screw jacks per machine, each fitted with double protective bellows and linked together with gearboxes, couplings and drive shafts.

Metal processing

Application: Raising and lowering a twin head brush adjustment mechanism and horizontal movement of the complete head to accommodate for brush wear on a tube end deburring machine.

Product: Six translating screw jacks per machine.

Glass packaging

Application: Raising and lowering a carriage clamping mechanism on a glass packaging machine operating on a continuous duty cycle.

Product: Four translating screw jacks, linked in an H configuration, fitted with two start screws and high performance gearsets to meet the speed and duty requirements.

Foam production

Application: Control of thickness, width and flow rate of block foam rubber on a foam forming machine.

Product: Six translating screw jacks per machine.

Table of contents

The jack range introduction	7-8
Cubic screw jacks—MULI®, JUMBO®	
Design versions	10-11
Technical data	12-15
Performance tables	16-17
Application design considerations	18-19
Selection and calculation	20-25
Duty factor graph	21
Screw buckling graph	22
Critical screw speed	23
System calculations	24-25
Outline drawing and tables of dimensions	26-27
Cubic screw jack accessories	28-37
Application checklist	38
How to order	39
Single-face screw jacks—RHINO	
Technical data	42-43
Technical data tables	
Metric (Trapezoidal screw jack and ball screw jack)	44
Imperial (ACME screw jack and ball screw jack)	45
Application design considerations	46-47
How to select a screw jack	48-73
Metric	48-51
Imperial	52-55
General information and systems	56
Jack selection tables	57-70
Metric trapezoidal screw jack	57-60
Metric ball screw jack	61-63
Imperial ACME screw jack	64-67
Imperial ball screw jack	68-70
Duty factor graph	71
Screw buckling graph	72
Critical screw speed	73
Outline drawings and tables of dimensions	74
Metric trapezoidal screw jack – translating	74-75
Metric trapezoidal screw jack – rotating	76-77
Metric ball screw jack – translating	78-79
Metric ball screw jack – rotating	80-81
Imperial ACME screw jack – translating	82-83
Imperial ACME screw jack – rotating	84-85
Imperial ball screw jack – translating	86-87
Imperial ball screw jack – rotating	88-89
Single face screw jack accessories	90-96
End fittings	90-91
Limit switches	92-93
Bellows	94-95
Application checklist	97
How to order	98-99
Metric	98
Imperial	99

The jack range

General introduction

This technical manual has been produced to provide a comprehensive guide to the selection, dimensioning and ordering of the Maryland Metrics offered range of screw jacks and accessories.

Maryland Metrics screw jacks are used wherever precisely controlled lifting, lowering, tilting and slewing movements are required in an efficient and reliable operation. They can be flexibly configured, either being installed as single units, in pairs, or as part of a multiple jack system and can be driven by an electric, hydraulic or pneumatic motor, or manually.

Many thousands of these screw jacks are operating successfully throughout the world in a wide variety of industries, including nuclear, automotive, communications, textile, food and drink, aerospace, metal processing, printing, offshore and marine, paper, glass and plastics.

Typical applications include, but are not limited to:

- scissor lifts
- lifting platforms
- shield door adjustment
- safety door operation
- test rigs
- steel levelling
- damper opening/closing
- antenna dish adjustment
- coiling/decoiling machines
- conveyor tracking
- roller adjustment (multi-industry)
- clamping mechanisms
- circast and continuous casting
- airbridges
- sluice gate control
- tundish car wreckers/de-scullers
- aircraft maintenance platforms

The extensive range of screw jacks is supported by a comprehensive range of complementary accessories and drive components, allowing a "one stop source" for full systems requirements. Where the standard product range does not meet customers' particular requirements, we are happy to design and manufacture fully customized units.

The highly qualified and specialized factory engineers are only a telephone call away and provide excellent technical customer support.

Screw jack characteristics

The standard range is comprised of: metric single-face screw jacks (trapezoidal and ball screw models), imperial single-face screw jacks (ACME and ball screw models) and metric cubic screw jacks (trapezoidal and ball screw models). Lifting capacities range from 5 kN (0.56 ton) models to 1000 kN (112 ton) models. Roller screw jacks and other special models are also available to meet any application requirement.

Screw jacks are designed for both tensile and compressive loads and will operate in any orientation or mounting position.

The positive characteristics of these screw jacks are as follows:

- Wide range of load capabilities
- High and low speeds available, according to the screw type and gearing
- Standard mounting arrangements and end fittings
- Ease of synchronization of several screw jacks
- Reliable self-locking action when in a stationary position (please check gear ratio and screw pitch)
- Special features include anti-rotation option, anti-backlash option, safety nut

The product ranges are designed and manufactured to BS EN ISO 9001 standards.

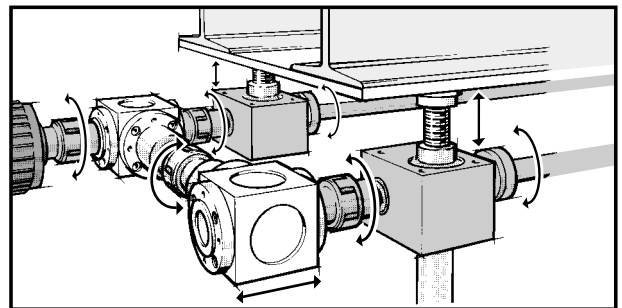

Lifting device for a bar-machining device

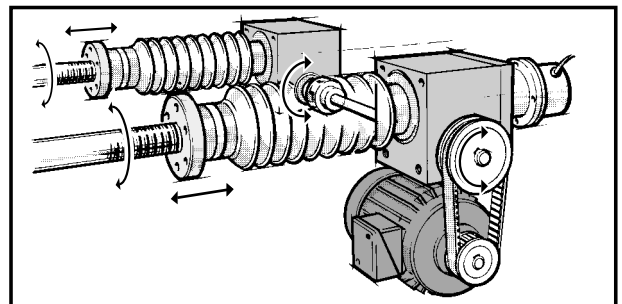

Positioning device

Types of screw jacks

There are two general design configurations available



Plain version

Axially translating screw (plain/keyed version)

Driven by precision worm gearing (wormshaft and internally threaded wormwheel), the rotary motion is converted into axial linear motion of the screw, which travels/translates through the gearbox housing. The load is attached to the end of the screw. Available in either an upright or inverted orientation in the following 2 versions:

Plain: Suitable where the load is permanently attached to the jack, which will prevent the screw from turning. Can be fitted with an anti-backlash feature.

Keyed: This is an anti-rotation version, suitable where the jack must move through free space before connecting with the load. In trapezoidal screw jacks, a milled slot in the screw is fitted with a key to prevent the screw from turning in free space. In ball screw jacks, a square guide is fitted to the end of the screw and runs within a square bottom pipe. Can be fitted with an anti-backlash feature.



Keyed version



Rotating screw with travelling nut (rotating version)

Driven by precision worm gearing (screw keyed to the wormwheel), the screw rotates and the travelling nut travels along it. The travelling nut carries the load. Available in either upright or inverted orientation and can be fitted with an anti-backlash feature.



Rotating version

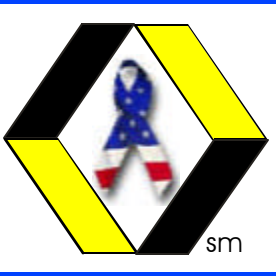

MARYLAND METRICS

phones: (800) 638-1830 (410) 358-3130
faxes: (800) 872-9329 (410) 358-3142

E-mail: sales@mdmetric.com URL: <http://mdmetric.com>

P.O.Box 261 Owings Mills, MD21117USA
6119 Oakleaf Avenue Baltimore, MD21215USA

Cubic Screw Jack Family
MULI[®], JUMBO[®]



Cubic face screw jacks

Design versions

MULI® 1
to
MULI® 5
5 to 100 kN
(0.56 to
11.2 tons)

Axially translating screw—version N or V

The rotary motion of precision worm gearing (worm shaft and internally threaded worm wheel) is converted into axial linear motion of the screw, which travels/translates through the gearbox housing. The load is attached to the end of the screw.

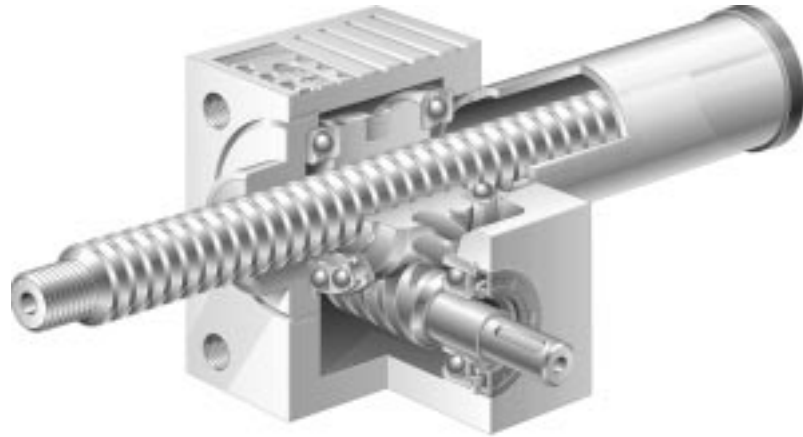

JUMBO® 1
to
JUMBO® 5
150 to 500 kN
(16.8 to
56 tons)

Rotating screw—version R

Driven by a precision worm gearing (screw keyed to the worm wheel), the rotary motion of the screw is translated into linear motion of the traveling nut on the screw.

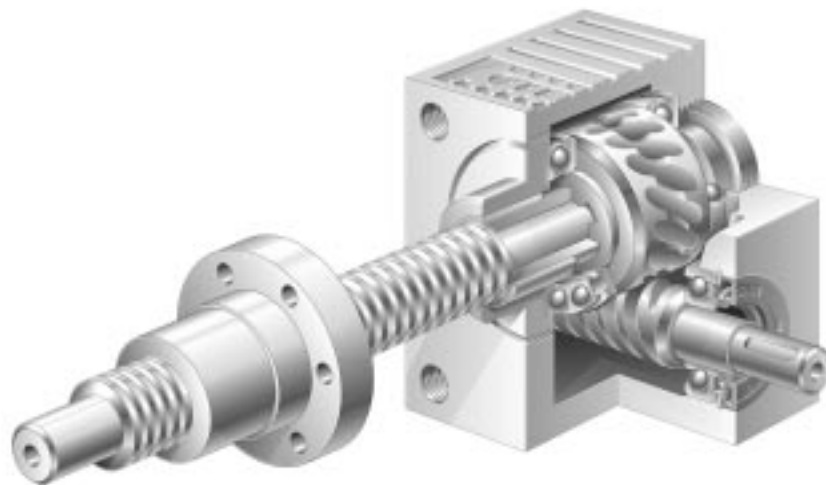

Version N

Rotation of the screw is prevented by its permanent attachment to the guide load.

Version V

Version V with anti-rotation device is recommended if the screw cannot be secured externally to prevent rotation.

Version R

Note:
The travelling nut must be ordered separately.

Gear ratio H

One full turn of the worm shaft produces a stroke of 1 mm (see pg. 14)

Gear ratio L

One full turn of the worm shaft produces a stroke of 0.25 mm (see pg. 14)

Trapezoidal screw

For tough conditions
Good price/performance ratio

Ball screw

For longer duty cycles
Higher efficiency
High positional accuracy

Redefining the performance limits with a new class of screw jacks

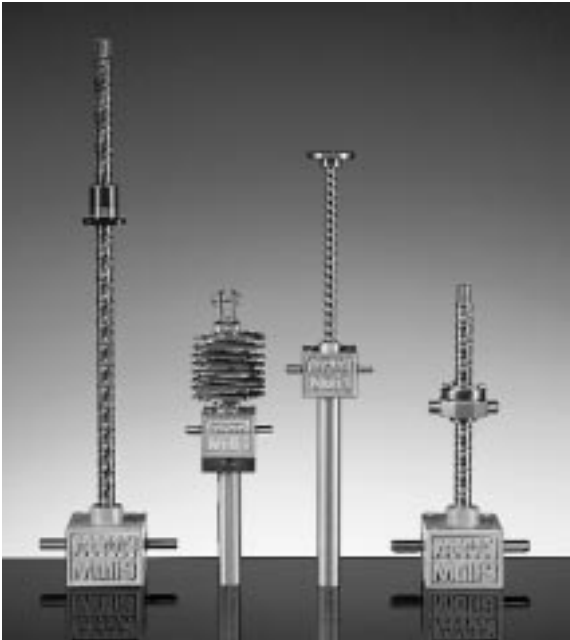

The range of Maryland Metrics worm gear screw jacks is comprised of ten models with lifting capacities from 5 kN to 500 kN (5.6 to 56 tons). All versions are designed for both tensile and compressive loads and will operate in any orientation or mounting position.

They meet the most demanding technical standards:

- Wide range of load capacities
- High and low speeds
- Cubic shape of the housing with predrilled flange bores allows ideal attachment of a motor, gearbox or rotary encoder
- Standard mounting parts and end fittings
- Easy synchronization of several worm gear screw jack units
- Ball screw or trapezoidal screw, as required for the application concerned
- Extensive variations can accommodate special requirements (e.g. safety nut)
- Complete range of accessories

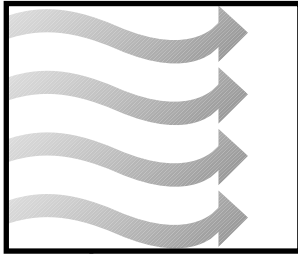

The design

The cubic shape with integrated cooling fins permits a longer duty cycle, as the heat is dissipated more effectively, thus extending the service life of the lubricant. The surface coating also protects the jack against corrosion.

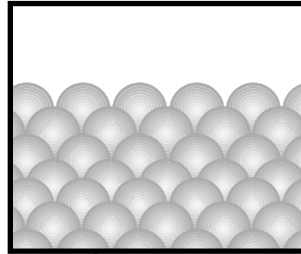

The housing material

The mechanical strength of the housing has been improved, particularly at high temperature, through the use of spheroidal graphite iron instead of the former cast iron. This ensures greater reliability, even in tough service conditions.

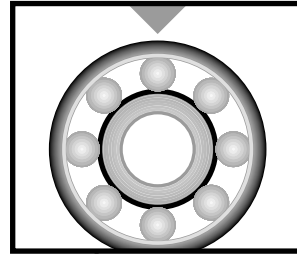

The bearings

Taper roller bearings on the worm shaft and heavy-duty ball bearings as the main thrust bearings make it possible to move higher loads, increase the safety reserve and extend the service life.

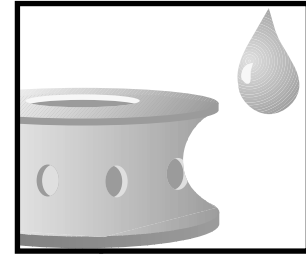

The lubrication

The trapezoidal screw (version N) is greased by radial lubrication holes on the worm wheel. This lowers friction and temperature and extends the service life, particularly when operating with longer stroke lengths.

Technical data

Cubic face screw jacks

The range includes a total of ten worm gear screw jack models in two series: MULI® 1 to MULI® 5 with lifting capacities up to 100 kN (11 tons) and JUMBO® 1 to JUMBO® 5 with lifting capacities from 150 kN (16 tons) to 500 kN (56 tons) statically.

Speed of travel

Gear ratio H (high speed)

For worm gear screw jacks fitted with standard trapezoidal screws, one full turn of the worm shaft produces a stroke of 1 mm and a linear speed of 1500 mm/minute at 1500 rpm. The figures for units fitted with ball screws range from 1071 mm/minute to 2142 mm/minute depending on size and pitch.

Gear ratio L (low speed)

For worm gear screw jacks fitted with standard trapezoidal screws, one full turn of the worm shaft produces a stroke of 0.25 mm and a linear speed of 375 mm/minute at 1500 rpm. The figures for units fitted with ball screws range from 312 mm/minute to 535 mm/minute depending on size and pitch.

Please note that higher speeds of travel can be achieved with larger screw pitches or multiple start screws.

Tolerances and backlash

- The gearbox housings are machined on the four mounting sides. The tolerances conform to DIN ISO 2768-mH. The sides that are not machined (the cooling ribs) conform to DIN 1685, GTB 18.
- The axial backlash of the jack screw under alternating load is as follows:
 - Trapezoidal screws: up to 0.4 mm
 - Ball screws: 0.08 mm
- The lateral play between the outside diameter of the screw and the guide diameter is 0.2 mm.
- The backlash in the worm gears is $\pm 4^\circ$ of the input shaft. A predetermined axial float is built into the input shaft bearing assembly of all models from MULI® 4 upwards to accommodate thermal expansion during operation.
- Trapezoidal screws are manufactured to a straightness of 0.3-1.5 mm/meter, ball screws to a straightness of 0.08 mm/meter over a length of 1000 mm and to the following pitch accuracies:
 - MULI® 1–MULI® 5:
0.05 mm/300 mm length
 - JUMBO® 1–JUMBO® 5:
0.2 mm/300 mm length

Lateral forces on the jack screw

Any lateral forces that may occur should be taken by an external guide rail.

Stop collar A

Prevents the screw from being removed from the jack gearbox. Fitted as standard on ball screw versions N and V. Optionally available for screw jacks with trapezoidal screws. The stop collar cannot be used as a fixed stop.

Self-locking

The self-locking function depends on a variety of parameters:

- Large pitches
- Different gear ratios
- Lubrication
- Friction parameters
- Ambient influences, such as high or low temperatures, vibrations, etc.
- The mounting position

Versions with ball screw and large pitches are consequently not self-locking. Suitable brakes or braking motors must therefore be considered in such cases. Limited self-locking is available for smaller pitches (single-start).

Special versions

In addition to the extensive standard range, Precision Technology USA, Inc. can also supply anti-clockwise, multi-start and special material worm gear screw jacks on request.

Technical data

Trapezoidal screws and ball screws

Trapezoidal screws

		MULI 1	MULI 2	MULI 3	MULI 4	MULI 5	JUMBO 1	JUMBO 2	JUMBO 3	JUMBO 4	JUMBO 5
Maximum lifting capacity [kN] ²⁾		5	10	25	50	100	150	200	250	350	500
Maximum lifting capacity [tons]		0.6	1.1	2.8	5.6	11.2	16.8	22.4	28.0	39.2	56.0
Screw diameter and pitch [mm]		18 x 4	20 x 4	30 x 6	40 x 7	55 x 9	60 x 9	70 x 10	80 x 10	100 x 10	120 x 14
Stroke in mm per full turn of the worm shaft	Ratio H ¹⁾	1	1	1	1	1	1	1	1	1	1
	Ratio L ¹⁾	0.25	0.25	0.25	0.25	0.25	0.25	0.25	0.25	0.25	0.25
Gear ratio	Ratio H ¹⁾	4:1	4:1	6:1	7:1	9:1	9:1	10:1	10:1	10:1	14:1
	Ratio L ¹⁾	16:1	16:1	24:1	28:1	36:1	36:1	40:1	40:1	40:1	56:1
Efficiency [%] ³⁾	Ratio H ¹⁾	31	29	29	26	24	23	22	20	19	19
	Ratio L ¹⁾	25	23	23	21	19	18	17	15	15	15
Weight [kg] (zero stroke)		1.2	2.1	6.0	17.0	32.0	41.0	57.0	57.0	85.0	160.0
Weight [kg per 100 mm stroke]		0.26	0.42	1.14	1.67	3.04	3.1	4.45	6.13	7.9	11.5
Idling torque [Nm]	H	0.04	0.11	0.15	0.35	0.84	0.88	1.28	1.32	1.62	1.98
	L	0.03	0.10	0.12	0.25	0.51	0.57	0.92	0.97	1.10	1.42

Ball screws

		MULI 1	MULI 2	MULI 3	MULI 4	MULI 5	JUMBO 3
Maximum lifting capacity [kN] ²⁾		5	10	12.5	22	42	78
Maximum lifting capacity [tons]		0.6	1.1	1.4	2.5	4.7	8.7
Screw diameter and pitch [mm]		1605	2005	2505	4005	4010	5010
Stroke in mm per full turn of the worm shaft	Ratio H ¹⁾	1.25	1.25	0.83	0.71	1.43	1.1
	Ratio L ¹⁾	0.31	0.31	0.21	0.18	0.36	0.28
Gear ratio	Ratio H ¹⁾	4:1	4:1	6:1		7:1	9:1
	Ratio L ¹⁾	16:1	16:1	24:1		28:1	36:1
Efficiency [%] ³⁾	Ratio H ¹⁾	57	56	55	53	56	47
	Ratio L ¹⁾	46	44	43	43	45	37
Weight [kg] (zero stroke)		1.3	2.3	7.0	19.0	35.0	63.0
Weight [kg per 100 mm stroke]		0.26	0.42	1.14	1.37	3.04	6.13
Idling torque [Nm]	H	0.04	0.11	0.15	0.35	0.84	1.32
	L	0.03	0.10	0.12	0.25	0.51	0.97

1) H = High speed, L = Low speed

2) Depending on speed of travel, operating hours, etc.

3) The specified efficiencies are average values

Technical data

Assembly and maintenance

Assembly of worm gear screw jack systems

Direction of rotation: Before starting assembly work, the direction of rotation of all worm gear screw jacks, bevel gearboxes and the drive motor must be checked with regard to the feed direction of each individual worm gear screw jack.

Alignment errors: All components must be carefully aligned during assembly. Alignment errors and stresses increase power consumption and lead to overheating and premature wear. Before a drive unit is attached, each worm gear screw jack should be turned through its entire length by hand without load. Variations in the amount of force required and/or axial marks on the outside diameter of the screw indicate alignment errors between the worm gear screw jack and its additional guides. In this case, the relevant mounting bolts must be loosened and the worm gear screw jack turned through by hand again. If the amount of force required is now constant throughout, the appropriate components are aligned.

If not, the alignment error must be localized by loosening additional mounting bolts.

Test run: The direction of rotation of the complete system and correct operation of the limit switches must be checked again before attaching the drive motor. In the case of version N (translating screw jack), check that the screw is lubricated with grease from the interior of the gearbox and lubricate if necessary. In the case of version R (rotating screw jack), the jack screw should be coated with suitable grease to

provide lubrication for lifting operation. The first test runs can then be carried out without load. A maximum operating time of 30% must not be exceeded at trial runs under weight for worm gear screw jacks with trapezoidal screws.

Operation: The loads, speeds and operating conditions specified for the worm gear screw jacks and transmission components must not be exceeded even briefly. Failure to observe this condition will invalidate all claims under guarantee.

Maintenance of worm gear screw jacks

Safety: All mounting bolts must be tightened after a short period of operation. The wear of the screw nut (worm gear) must be checked by measuring the thread backlash after approximately 200 hours of operation or sooner if operating conditions are harsh. The screw nut (worm gear) must be replaced if the axial backlash with a single-start thread is more than one-quarter of the thread pitch.

Lubrication: The worm gear screw jacks are lubricated by the manufacturer and are ready for operation on delivery. The versions N and V must be lubricated via their grease nipples with one of the greases specified below at intervals of 30 - 50 operating hours. The screw should be cleaned and greased at the same time. The service life of screw and screw nut can be extended by applying screw spray, particularly before being greased for the first time. We recommend that the gearbox be cleaned to remove old grease and refilled with fresh grease after approximately 700 operating hours

or 18 months. The worm gear screw jacks can be dismantled relatively easily:

- Unscrew the two threaded pins securing the bearing cover.
- Unscrew the screw and remove the screw protection if necessary.
- Unscrew the bearing cover with the aid of an open-ended spanner.

Proceed as follows to refit the bearing cover: fit the bearing cover firmly (using approximately ten times the force shown in the table "Guideline values for fitting bearing cover"). Then release it and refit it with the guideline value from the table, checking the axial backlash and smoothness.

Standard grease:
Lithogrease G 421

Recommended or equivalent greases:
Castrol Spheerol BM2
Mobil Mobilgrease XHP
Shell retinax HD2

Guideline values for fitting bearing cover

Size	Torque [Nm]
MULI® 1	5
MULI® 2	9
MULI® 3	13
MULI® 4	32
MULI® 5	60
JUMBO® 1	70
JUMBO® 2	150
JUMBO® 3	150
JUMBO® 4	220
JUMBO® 5	300

Performance tables for MULI® worm gear screw jacks

MULI® 1 – MULI® 5 with gear ratio H and L, with single-start trapezoidal screw and 20% duty cycle per hour at a normal temperature of 20° C (68 °F).

The screw jacks can overheat or have an excessive area pressure develop in the screw thread at the speeds stated in the shaded fields. Precision Technology USA, Inc. cannot assume any liability for this range.

MULI® 2 – screw Tr 18 x 4 Lifting force (kN)

Speed [rpm]	Lifting speed [mm/min]		5		4		3		2		1.5		1													
	H	L	H	L	H	L	H	L	H	L	H	L	H	L												
1500	1500	375	2.61	0.41	0.83	0.13	2.09	0.33	0.67	0.10	1.58	0.25	0.51	0.08	1.07	0.17	0.35	0.05	0.81	0.13	0.27	0.04	0.55	0.09	0.19	0.03
1000	1000	250	2.61	0.27	0.83	0.09	2.09	0.22	0.67	0.07	1.58	0.17	0.51	0.05	1.07	0.11	0.35	0.04	0.81	0.08	0.27	0.03	0.55	0.06	0.19	0.02
750	750	187	2.61	0.20	0.83	0.06	2.09	0.16	0.67	0.05	1.58	0.12	0.51	0.04	1.07	0.08	0.35	0.03	0.81	0.06	0.27	0.02	0.55	0.04	0.19	0.01
500	500	125	2.61	0.14	0.83	0.04	2.09	0.11	0.67	0.03	1.58	0.08	0.51	0.03	1.07	0.06	0.35	0.02	0.81	0.04	0.27	0.01	0.55	0.03	0.19	0.01

MULI® 2 – screw Tr 20 x 4 Lifting force (kN)

Speed [rpm]	Lifting speed [mm/min]		10		7.5		5		4		3		2													
	H	L	H	L	H	L	H	L	H	L	H	L	H	L												
1500	1500	375	5.60	0.88	1.83	0.29	4.23	0.66	1.40	0.22	2.86	0.45	0.97	0.15	2.31	0.36	0.79	0.12	1.76	0.28	0.62	0.10	1.21	0.19	0.45	0.07
1000	1000	250	5.60	0.59	1.83	0.19	4.23	0.44	1.40	0.15	2.86	0.30	0.97	0.10	2.31	0.24	0.79	0.08	1.76	0.18	0.62	0.06	1.21	0.13	0.45	0.05
750	750	187	5.60	0.44	1.83	0.14	4.23	0.33	1.40	0.11	2.86	0.22	0.97	0.08	2.31	0.18	0.79	0.06	1.76	0.14	0.62	0.05	1.21	0.09	0.45	0.04
500	500	125	5.60	0.29	1.83	0.10	4.23	0.22	1.40	0.07	2.86	0.15	0.97	0.05	2.31	0.12	0.79	0.04	1.76	0.09	0.62	0.03	1.21	0.06	0.45	0.02

MULI® 3 – screw Tr 30 x 6 Lifting force (kN)

Speed [rpm]	Lifting speed [mm/min]		25		20		15		10		5		2.5													
	H	L	H	L	H	L	H	L	H	L	H	L	H	L												
1500	1500	375	13.88	2.18	4.45	0.70	11.13	1.75	3.58	0.56	8.39	1.32	2.72	0.43	5.64	0.89	1.85	0.29	2.90	0.45	0.99	0.15	1.52	0.24	0.55	0.09
1000	1000	250	13.88	1.45	4.45	0.47	11.13	1.17	3.58	0.38	8.39	0.88	2.72	0.28	5.64	0.59	1.85	0.19	2.90	0.30	0.99	0.10	1.52	0.16	0.55	0.06
750	750	187	13.88	1.09	4.45	0.35	11.13	0.87	3.58	0.28	8.39	0.66	2.72	0.21	5.64	0.44	1.85	0.15	2.90	0.23	0.99	0.08	1.52	0.12	0.55	0.04
500	500	125	13.88	0.73	4.45	0.23	11.13	0.58	3.58	0.19	8.39	0.44	2.72	0.14	5.64	0.30	1.85	0.10	2.90	0.15	0.99	0.05	1.52	0.08	0.55	0.03

MULI® 4 – screw Tr 40 x 7 Lifting force (kN)

Speed [rpm]	Lifting speed [mm/min]		50		40		30		20		10		5													
	H	L	H	L	H	L	H	L	H	L	H	L	H	L												
1500	1500	375	30.97	4.86	9.73	1.53	24.85	3.90	7.83	1.23	18.72	2.94	5.94	0.93	12.60	1.98	4.04	0.63	6.47	1.02	2.15	0.34	3.41	0.54	1.20	0.19
1000	1000	250	30.97	3.24	9.73	1.03	24.85	2.60	7.83	0.82	18.72	1.96	5.94	0.62	12.60	1.32	4.04	0.42	6.47	0.68	2.15	0.22	3.41	0.36	1.20	0.13
750	750	187	30.97	2.43	9.73	0.76	24.85	1.95	7.83	0.62	18.72	1.47	5.94	0.47	12.60	0.99	4.04	0.32	6.47	0.51	2.15	0.17	3.41	0.27	1.20	0.09
500	500	125	30.97	1.62	9.73	0.51	24.85	1.30	7.83	0.41	18.72	0.98	5.94	0.31	12.60	0.66	4.04	0.21	6.47	0.34	2.15	0.11	3.41	0.18	1.20	0.06

MULI® 5 – screw Tr 55 x 9 Lifting force (kN)

Speed [rpm]	Lifting speed [mm/min]		100		80		60		40		20		10													
	H	L	H	L	H	L	H	L	H	L	H	L	H	L												
1500	1500	375	67.19	10.55	21.46	3.37	53.92	8.47	7.27	2.71	40.65	6.38	13.08	2.05	27.38	4.30	8.89	1.40	14.11	2.22	4.70	0.74	7.47	1.17	2.61	0.41
1000	1000	250	67.19	7.04	21.46	2.25	53.92	5.65	7.27	1.81	40.65	4.26	13.08	1.37	27.38	2.87	8.89	0.93	14.11	1.48	4.70	0.49	7.47	0.78	2.61	0.27
750	750	187	67.19	5.28	21.46	1.69	53.92	4.23	7.27	1.36	40.65	3.19	13.08	1.03	27.38	2.15	8.89	0.70	14.11	1.11	4.70	0.37	7.47	0.59	2.61	0.20
500	500	125	67.19	3.52	21.46	1.12	53.92	2.82	7.27	0.90	40.65	2.13	13.08	0.68	27.38	1.43	8.89	0.47	14.11	0.74	4.70	0.25	7.47	0.39	2.61	0.14

Performance tables for JUMBO® worm gear screw jacks

JUMBO® 1 – JUMBO® 5 with gear ratio H and L, with single-start trapezoidal screw and 20% duty cycle per hour at a normal temperature of 20° C (68 °F).

The screw jacks can overheat or have an excessive area pressure develop in the screw thread at the speeds stated in the shaded fields. Precision Technology USA, Inc. cannot assume any liability for this range.

JUMBO® 1 – screw Tr 60 x 9 Lifting force (kN)

Speed [rpm]	Lifting speed [mm/min]		150		100		80		60		40		20													
	H	L	[Nm] [kW]	[Nm] [kW]	[Nm] [kW]	[Nm] [kW]	[Nm] [kW]	[Nm] [kW]	[Nm] [kW]	[Nm] [kW]	[Nm] [kW]	[Nm] [kW]	[Nm] [kW]	[Nm] [kW]												
1500	1500	375	104.73	16.45	33.74	5.30	70.11	11.01	22.69	3.56	56.27	8.84	18.26	2.87	42.42	6.66	13.84	2.17	28.57	4.49	9.42	1.48	14.73	2.31	4.99	0.78
1000	1000	250	104.73	10.97	33.74	3.53	70.11	7.34	22.69	2.38	56.27	5.89	18.26	1.91	42.42	4.44	13.84	1.45	28.57	2.29	9.42	0.99	14.73	1.54	4.99	0.52
750	750	187	104.73	8.22	33.74	2.65	70.11	5.51	22.69	1.78	56.27	4.42	18.26	1.43	42.42	3.33	13.84	1.09	28.57	2.24	9.42	0.74	14.73	1.16	4.99	0.39
500	500	125	104.73	5.48	33.74	1.77	70.11	3.67	22.69	1.19	56.27	2.95	18.26	0.96	42.42	2.22	13.84	0.72	28.57	1.50	9.42	0.49	14.73	0.77	4.99	0.26

JUMBO® 2 – screw Tr 70 x 10 Lifting force (kN)

Speed [rpm]	Lifting speed [mm/min]		200		170		130		100		75		50													
	H	L	[Nm] [kW]	[Nm] [kW]	[Nm] [kW]	[Nm] [kW]	[Nm] [kW]	[Nm] [kW]	[Nm] [kW]	[Nm] [kW]	[Nm] [kW]	[Nm] [kW]	[Nm] [kW]	[Nm] [kW]												
1500	1500	375	146.04	22.94	47.75	7.50	124.33	19.53	40.73	6.40	95.37	14.98	31.36	4.93	73.66	11.57	24.34	3.82	55.56	8.73	18.48	2.90	30.47	5.89	12.63	1.98
1000	1000	250	146.04	15.29	47.75	5.00	124.33	13.02	40.73	4.26	95.37	9.99	31.36	3.28	73.66	7.71	24.34	2.55	55.56	5.82	18.48	1.94	30.47	3.92	12.63	1.32
750	750	187	146.04	11.47	47.75	3.75	124.33	9.76	40.73	3.20	95.37	7.49	31.36	2.46	73.66	5.78	24.34	1.91	55.56	4.36	18.48	1.45	30.47	2.94	12.63	0.99
500	500	125	146.04	7.65	47.75	2.50	124.33	6.31	40.73	2.13	95.37	4.99	31.36	1.64	73.66	3.86	24.34	1.27	55.56	2.91	18.48	0.97	30.47	1.96	12.63	0.66

JUMBO® 3 – screw Tr 80 x 10 Lifting force (kN)

Speed [rpm]	Lifting speed [mm/min]		250		200		160		130		100		75													
	H	L	[Nm] [kW]	[Nm] [kW]	[Nm] [kW]	[Nm] [kW]	[Nm] [kW]	[Nm] [kW]	[Nm] [kW]	[Nm] [kW]	[Nm] [kW]	[Nm] [kW]	[Nm] [kW]	[Nm] [kW]												
1500	1500	375	200.00	31.47	67.32	10.57	160.56	25.22	54.05	8.49	128.71	20.22	43.43	6.82	104.82	16.46	35.47	5.37	80.94	12.71	27.51	4.32	61.03	9.59	20.87	3.28
1000	1000	250	200.00	20.98	67.32	7.05	160.56	16.81	54.05	5.66	128.71	13.48	43.43	4.55	104.82	10.98	35.47	3.71	80.94	8.48	27.51	2.88	61.03	6.39	20.87	2.19
750	750	187	200.00	15.74	67.32	5.29	160.56	12.61	54.05	4.24	128.71	10.11	43.43	3.41	104.82	8.23	35.47	2.79	80.94	6.36	27.51	2.16	61.03	4.79	20.87	1.64
500	500	125	200.00	10.49	67.32	3.52	160.56	8.41	54.05	2.83	128.71	6.74	43.43	2.27	104.82	5.49	35.47	1.86	80.94	4.24	27.51	1.44	61.03	3.20	20.87	1.09

JUMBO® 4 – screw Tr 100 x 10 Lifting force (kN)

Speed [rpm]	Lifting speed [mm/min]		350		300		250		200		150		100													
	H	L	[Nm] [kW]	[Nm] [kW]	[Nm] [kW]	[Nm] [kW]	[Nm] [kW]	[Nm] [kW]	[Nm] [kW]	[Nm] [kW]	[Nm] [kW]	[Nm] [kW]	[Nm] [kW]	[Nm] [kW]												
1500	1500	375	294.25	46.33	93.99	14.76	253.04	39.75	80.72	12.68	211.14	33.16	67.45	10.59	169.24	26.58	54.18	8.51	127.33	20.00	40.91	6.43	85.43	13.42	27.64	4.34
1000	1000	250	294.25	30.83	93.99	9.84	253.04	26.50	80.72	8.45	211.14	22.11	67.45	7.06	169.24	17.72	54.18	5.67	127.33	13.33	40.91	4.28	85.43	8.95	27.64	2.89
750	750	187	294.25	23.16	93.99	7.38	253.04	19.87	80.72	6.34	211.14	16.58	67.45	5.3	169.24	13.29	54.18	4.25	127.33	10.00	40.91	3.21	85.43	6.71	27.64	2.17
500	500	125	294.25	15.44	93.99	4.92	253.04	13.25	80.72	4.23	211.14	11.05	67.45	3.53	169.24	8.86	54.18	2.84	127.33	6.67	40.91	2.14	85.43	4.47	27.64	1.45

JUMBO® 5 – screw Tr 120 x 14 Lifting force (kN)

Speed [rpm]	Lifting speed [mm/min]		500		400		300		200		100		50													
	H	L	[Nm] [kW]	[Nm] [kW]	[Nm] [kW]	[Nm] [kW]	[Nm] [kW]	[Nm] [kW]	[Nm] [kW]	[Nm] [kW]	[Nm] [kW]	[Nm] [kW]	[Nm] [kW]	[Nm] [kW]												
1500	1500	375	421.02	66.13	134.12	21.07	337.21	52.97	107.58	16.90	253.40	39.80	81.04	12.73	169.60	26.64	54.50	8.56	85.79	13.47	27.69	4.39	43.88	6.89	14.69	2.31
1000	1000	250	421.02	44.09	134.12	14.04	337.21	35.31	107.58	11.26	253.40	26.53	81.04	8.49	169.60	17.76	54.50	5.71	85.79	8.98	27.69	2.93	43.88	4.60	14.69	1.54
750	750	187	421.02	33.06	134.12	10.53	337.21	26.48	107.58	8.45	253.40	19.90	81.04	6.36	169.60	13.32	54.50	4.28	85.79	6.74	27.69	2.20	43.88	3.45	14.69	1.15
500	500	125	421.02	22.04	134.12	7.02	337.21	17.66	107.58	5.63	253.40	13.27	81.04	4.24	169.60	8.88	54.50	2.85	85.79	4.49	27.69	1.46	43.88	2.30	14.69	0.77

Application design considerations

Planning of screw jack systems



The procedure for planning screw jack systems is generally as follows:

1. Definition of the speed and possible mounting positions of the worm gear screw jacks.
2. Selection of the drive components (couplings, shafts, bevel gearboxes, motors) for synchronous drive of the individual worm gear screw jacks. The following criteria are decisive:
 - Lowest possible loading of the individual transmission components. Input of the entire drive torque via the teeth of a bevel gearbox must be avoided in particular.
 - As few transmission components as possible and short connecting shafts.
 - Provision for the use of a torque-limiting coupling to protect the system.

It is sometimes difficult to show the direction of rotation of the individual components in the drawing. The following method can generally be used to good effect:

- Define the position of the individual worm gear screw jacks.
- Enter the direction of rotation of each worm gear screw jack for the lifting motion (the direction of rotation of a shaft is shown by an arrow pointing in the direction of movement of a point on the upper side of the shaft).
- Draw the possible position of the bevel gearboxes.
- Determine the direction of rotation and position.

Application design considerations

Examples: direction of rotation

Fig. 1

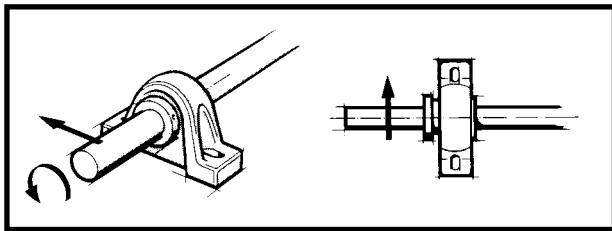

Fig. 1:
Illustration of direction of rotation

Fig. 2

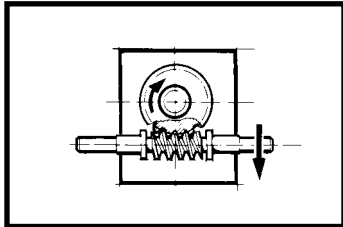

Fig. 2:
Direction of rotation of a worm gear screw jack for lifting motion, top view.

Fig. 3

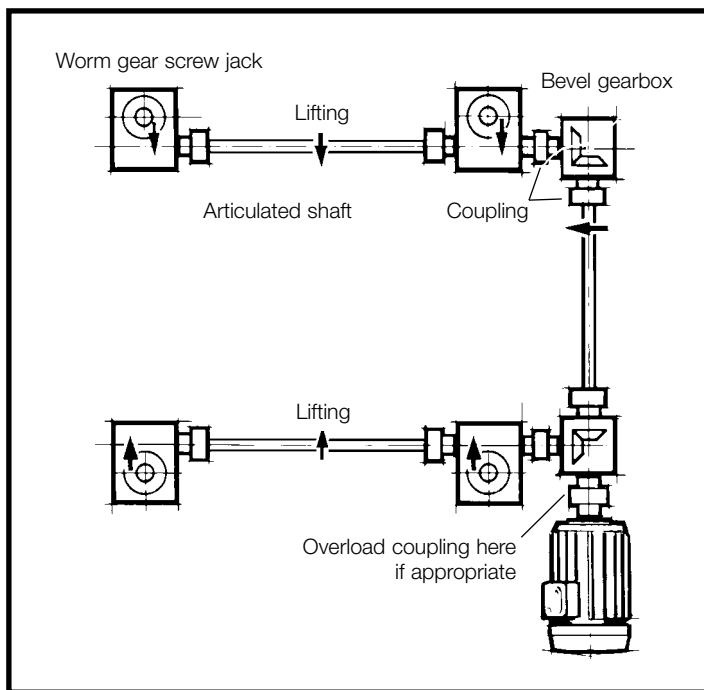

Fig. 3:
Jack system with four worm gear screw jacks and two bevel gearboxes

Fig. 4 (left)

Fig. 5 (right)

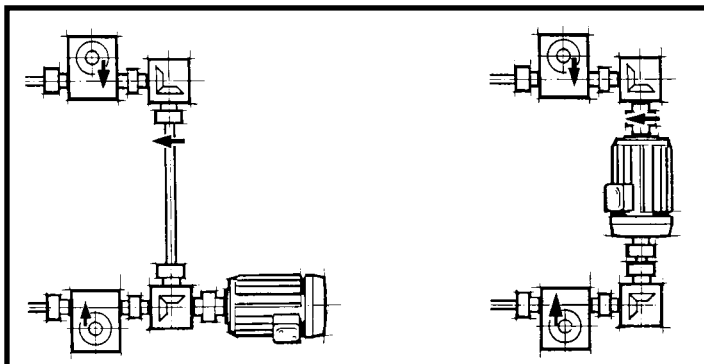

Fig. 4:
Jack system, variant 1:
Different position of drive motor,
but only ratio 1:1 possible.
Overload coupling also possible.

Fig. 5:
Jack system, variant 2:
Very economical, but overload
coupling not possible.

Selection and calculation

Selection of a worm gear screw jack and corresponding drive unit

After selecting the drive unit, it is important to check whether the worm gear screw jack or any transmission components may be overloaded by the drive unit (see page 25).

The following points should also be established:

1. On which side is the motor to be mounted
2. Direction of rotation of the jack systems

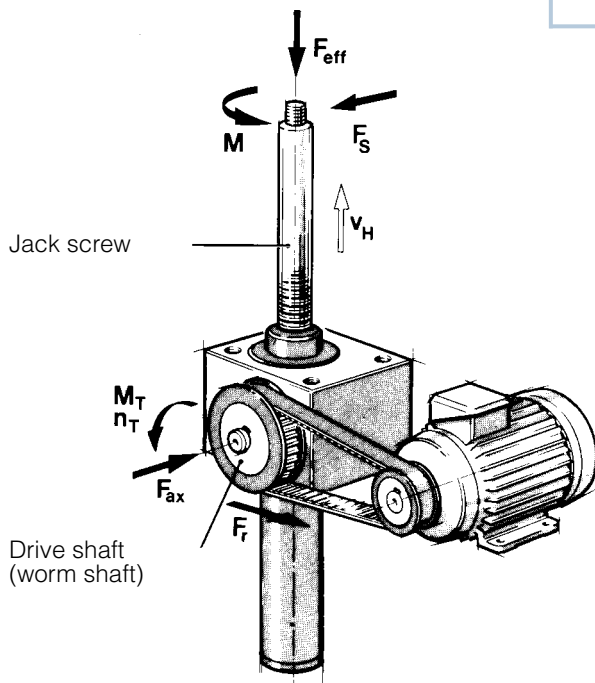

Forces and torque values acting on the worm gear screw jack (See figure above)

Note: Forces and torque values can only be estimated by making simplified assumptions. The coefficients of friction of sliding pairs, the heat which these generate and the resultant service life depend on load, speed, temperature and lubrication conditions. Critical speeds

and buckling lengths depend on the rigidity and mass of the clamping systems, machine frames, etc. The results of calculations should therefore be examined critically with regard to the assumptions made. Please contact us if in doubt.

F_{eff} = Axial force acting on the jack screw

F_S = Result of all lateral forces acting on the jack screw

M = Torque of the jack screw or nut (not applicable in the case of version V)

V_H = Lifting speed

F_{ax} = Axial force acting on drive shaft

F_r = Radial force acting on drive shaft

M_T = Drive torque

n_T = Drive speed

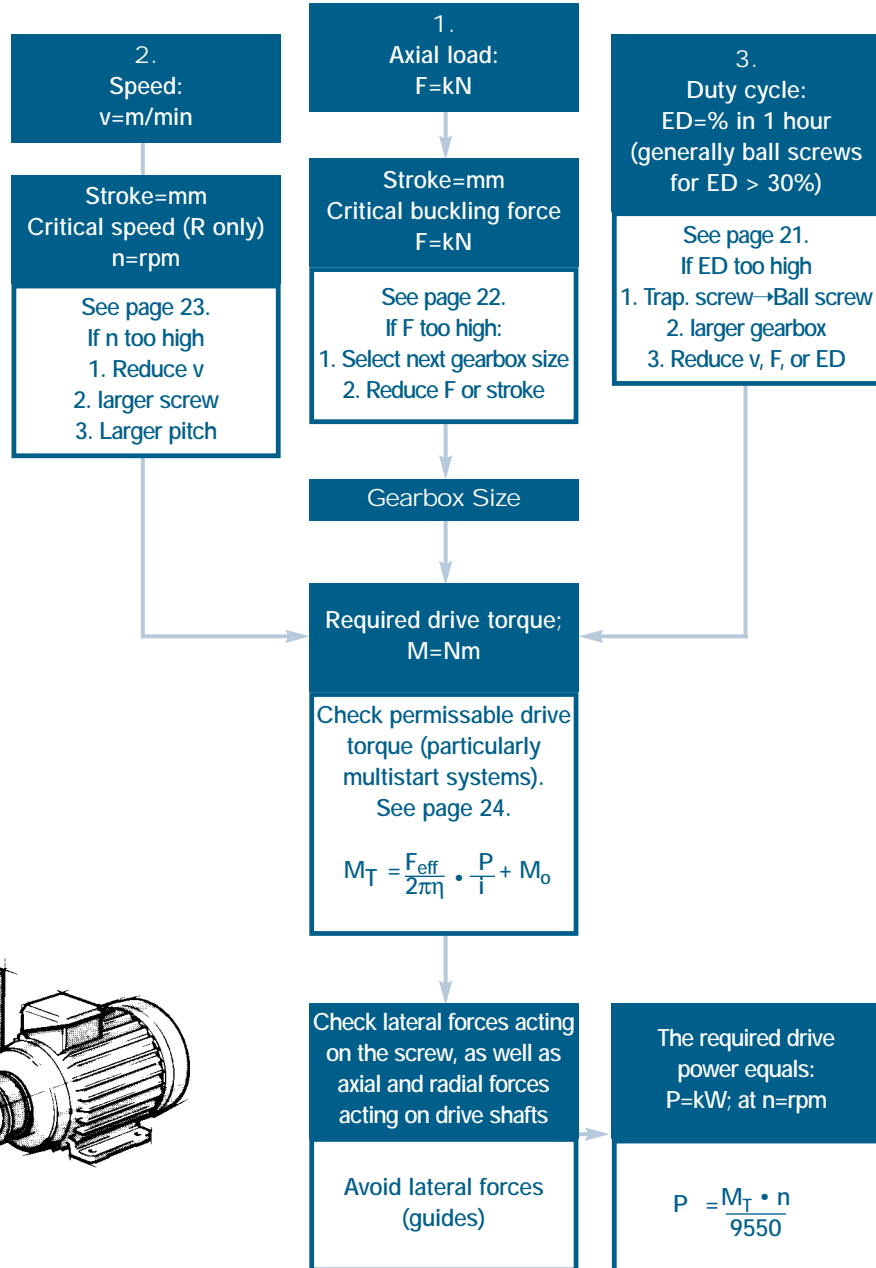

Selection and calculation

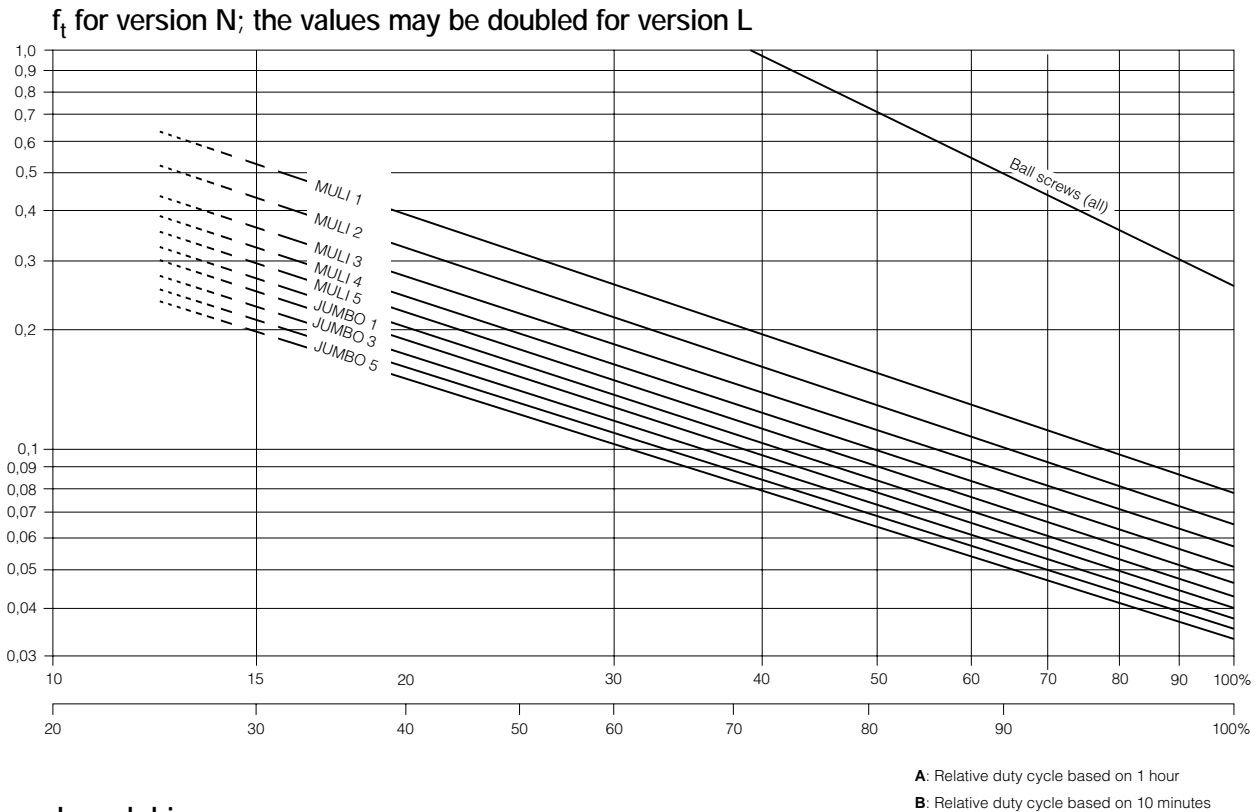

Duty cycle and drive power

In order to limit the heat generated by friction within a worm gear screw jack, the lifting force and lifting speed are limited as a function of the relative duty cycle. The maximum permissible lifting force and lifting speed can be estimated with the aid of the following method.

$$F_{\text{eff}} \cdot V_H \leq F_{\text{stroke max}} \cdot V_{H \text{ max}} \cdot f_t$$

F_{eff} Actual axial force acting on the jack screw in kN.

V_H Lifting speed in mm/min.

$F_{\text{stroke max}}$ Maximum permissible lifting force in kN (see table on page 14).

$V_{H \text{ max}}$ Maximum permissible lifting speed in mm/min. It is calculated from the maximum permissible speed of the worm shaft of 1500 rpm (higher speeds on request) and the transmission ratio of the worm gear screw jack.

f_t Temperature factor which is dependent on the relative duty factor based on a period of 10 or 60 minutes at 20 °C.

The values determined here do not apply for very short reciprocating strokes. Please consult us in such cases. f_t can be extrapolated to the left-hand edge of the graph in the case of very low relative duty cycles (less than 10 minutes – for occasional positioning operations, adjustments of levels, etc.). This yields the following approximate drive power values in kW with allowance for the efficiency in each case.

	MULI 1	MULI 2	MULI 3	MULI 4	MULI 5	JUMBO 1	JUMBO 2	JUMBO 3	JUMBO 4	JUMBO 5
Ratio H (Trapezoidal)	0.3	0.55	1.18	2.3	4.7	6.5	8.4	10.9	14.7	19
Ratio L (Trapezoidal)	0.19	0.35	0.75	1.4	3	4.2	5.4	7.3	9.3	12
Ball screws	0.3	0.56	0.95	1.7/3.2	5.9	-	-	13.9	-	-

These values are not a criterion for selecting the drive motor; it should be selected on the basis of torque, speed and operating conditions.

Selection and calculation

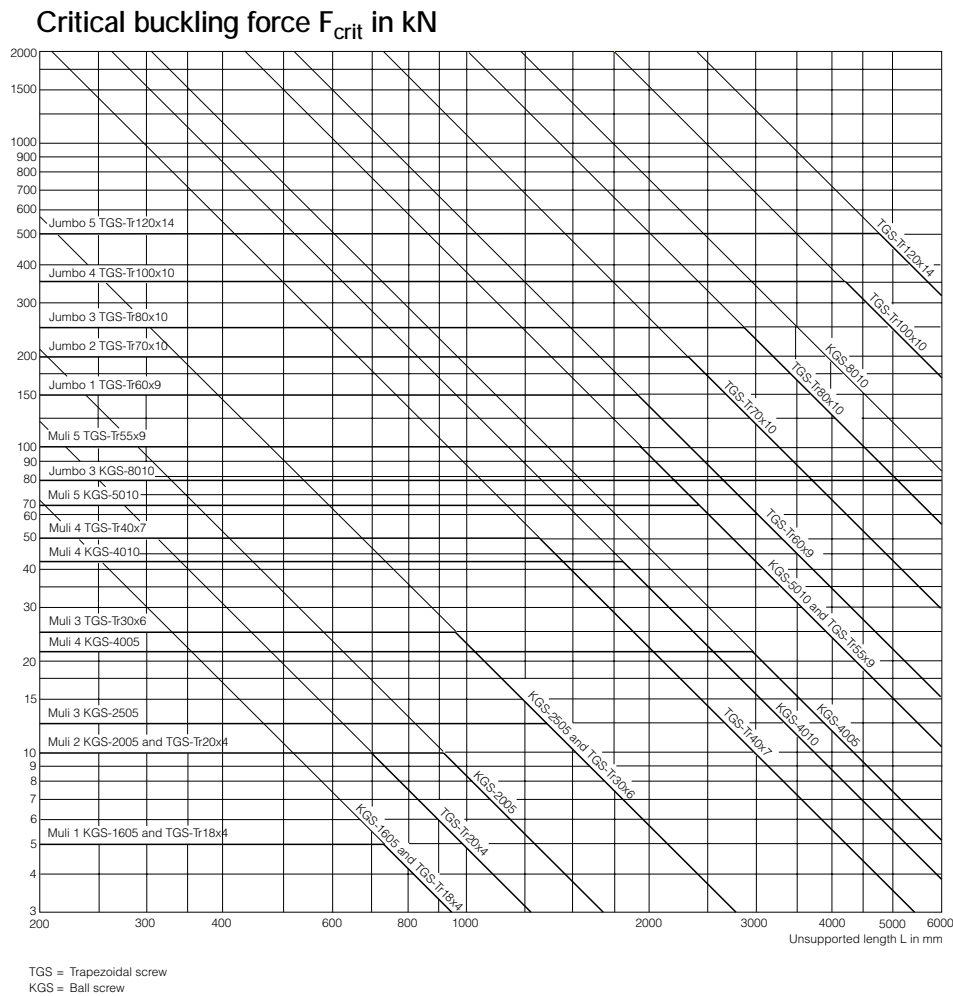

Critical buckling force of a screw jack under compressive loads

Thin lifting screws may buckle sideways when subjected to compressive loads. Before the permissible compressive force is defined for the screw, allowances must be made for safety factors as appropriate to the installation.

$$F_{eff} \leq f_k \cdot F_{crit} \cdot 1/S_k$$

F_{eff} Actual axial force (compressive force) acting on the jack screw in kN.

f_k Correction factor which makes allowance for the type of screw bearing. Sufficiently rigid mounting of the worm gear screw jack is required for cases 2, 3 and 4.

F_{crit} Critical buckling force as a function of the unsupported length L .

S_k Safety factor that depends on the application in question. Values between 3 and 6 are customary in general mechanical engineering.

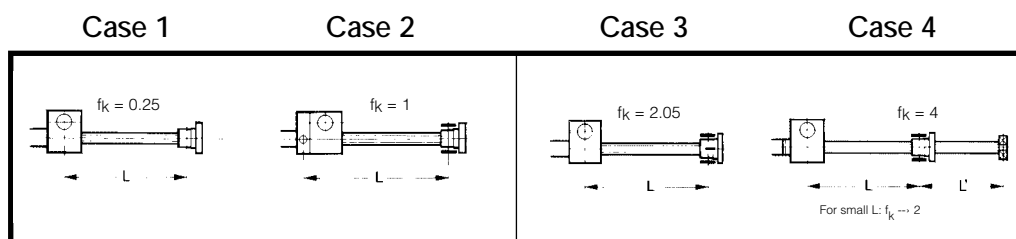

Selection and calculation

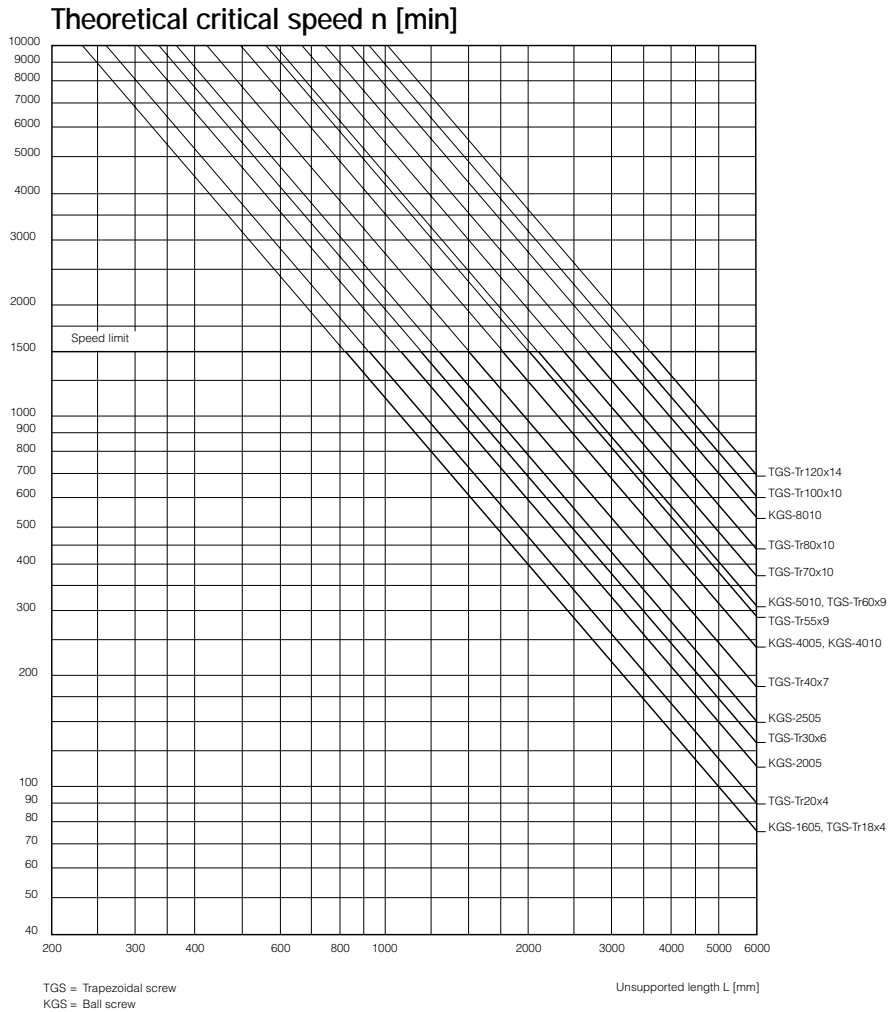

Critical speed of jack screws (version R only)

Resonant bending vibration may develop with thin screws rotating at high speed. Assuming a sufficiently rigid assembly, the resonant frequency can be estimated with the aid of the following method.

$$n_{\text{perm}} = f_{\text{kr}} \cdot n_{\text{crit}} \cdot 0.8$$

n_{perm} Maximum permissible screw speed in rpm.

f_{kr} Correction factor which makes allowance for the type of screw bearing. Sufficiently rigid mounting of the worm gear screw jack and bearing is required for cases 2, 3 and 4.

n_{crit} Critical screw speed. Corresponds to the basic bending vibration of the screw and leads to resonance effects.

Case 1

Case 2

Case 3

Case 4

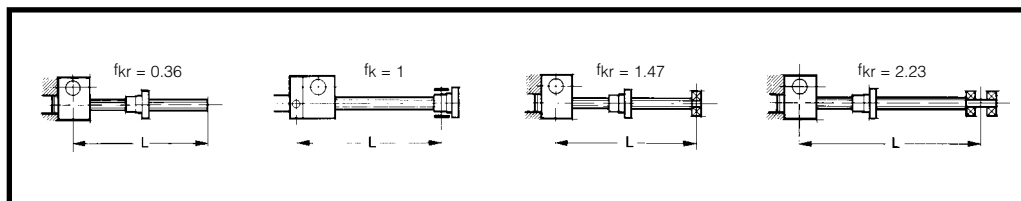

Worm gear screw jacks with multi-start screws are also available for applications with high lifting speeds. These versions run at a considerably lower screw speed with better efficiency for the same lifting speed. They are generally not self-locking.

Selection and calculation

Required drive torque for a worm gear screw jack

The required drive torque for a worm gear screw jack is governed by the axial load acting on the jack screw, the transmission ratio and the efficiency. It should be noted that the breakaway torque may be considerably higher than the torque required for continuous running. This applies in particular to worm gear screw jacks with low efficiency after a long standstill period. The acceleration torque should be checked if necessary in cases with large screw pitches and very short run-up times.

$$M_T = \frac{F_{\text{eff}}}{2 \cdot \pi \cdot \eta} \cdot \frac{P}{i} + M_O$$

M_T	Required drive torque of the worm gear screw drive at the worm shaft in Nm.	η	Efficiency of the worm gear screw jack in decimal notation. e.g. 0.32 instead of 32% (for values, see table on page 11). η is an average value determined by measurement.	grease lubrication at room temperature. It represents an average value which may vary to a greater or lesser extent, depending on the running-in state, lubricant and temperature. For values, see table on page 14.
F_{eff}	Actual force acting on the jack screw in kN.			
$\frac{P}{i}$	Transmission ratio of the worm gear screw drive in mm stroke length per revolution of the worm shaft.	M_O	Idle torque of the worm gear screw drive in Nm. M_O is determined by measurements undertaken after a brief running-in period with liquid	

Required drive torque for a worm gear screw jack system

The required drive torque for a worm gear screw jack system is governed by the drive torque values for the individual jacks, with allowance for the static and dynamic frictional losses in transmission components (coupling, connecting shafts, pedestal bearings, angle gearboxes, etc.). It is useful to draw a diagram illustrating the flow of forces.

$M_{T \text{ SHG1}}$	The required drive torque for the worm gear screw jack SHG 1. It should be noted that the start-up torque (breakaway torque and possibly acceleration torque) may be considerably higher than the torque required for continuous running. This applies in particular to worm gear screw jacks with low efficiency after a long standstill period.	η_{V1}	The efficiency of connecting shaft V1.	η_K	The efficiency of the bevel gearbox (only for the force flow via the toothing, i.e. between connecting shaft V2 and the drive motor). $\eta_K = 0.90$
		η_{V2}	(V2) includes the static and dynamic frictional losses in the pedestal bearings and couplings.		
		η_V	0.75...0.95 depending on the length of the shaft and number of pedestal bearings.		

Example

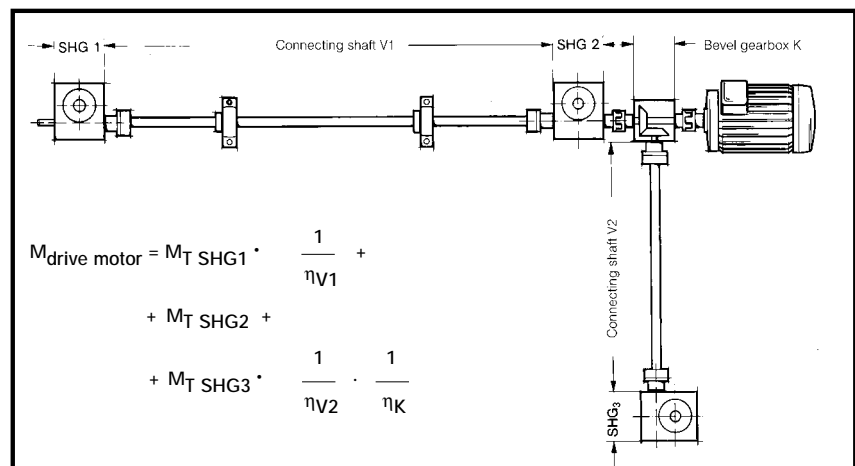

Selection and calculation

Maximum drive torque

If the worm gear screw jack jams as a result of the screw coming into contact with an obstacle, the teeth can still absorb the following maximum torque values M_T at the drive shaft.

In the case of screw jacks connected in series, the screw jack closest to the drive can absorb this torque at its drive shaft.

Size	M_T max [Nm]
MULI® 1	3.4
MULI® 2	7.1
MULI® 3	18
MULI® 4	38
MULI® 5	93
JUMBO® 1	148
JUMBO® 2	178
JUMBO® 3	240
JUMBO® 4	340
JUMBO® 5	570

Forces and torque values acting on the drive shaft

If worm gear screw jacks are not driven free of lateral forces by means of a coupling connected to the motor shaft, but are instead driven by chains or belts, care must be taken to ensure that the radial force acting on the drive shaft does not become excessive. The values are specified in the following table.

In the worst case, the worm shaft will bend under radial force F_R and lift off the worm gear. This must be avoided, since it impairs the engagement between worm shaft and worm gear and leads to higher wear.

Size	F_R max [kN]
MULI® 1	0.1
MULI® 2	0.2
MULI® 3	0.3
MULI® 4	0.5
MULI® 5	0.8
JUMBO® 1	0.8
JUMBO® 2	1.3
JUMBO® 3	1.3
JUMBO® 4	2.1
JUMBO® 5	3.1

Selection of drive motor

A suitable drive motor can be selected when the required drive torque and drive speed are known. After selecting a drive motor, check that it will not overload any of the worm gear screw jacks or transmission components. This risk may occur, in particular, in installations with several screw jacks if they are loaded unevenly. It will generally be necessary to install limit switches or torque-limiting couplings to protect the installation against impacting against end positions and obstacles.

Forces and torque values on the motor shaft

Toothed-belt or chain drives may exert considerable radial forces on the motor shaft if a very small sprocket is used. Please consult the motor manufacturer in cases of doubt.

Selection of a bevel gearbox

Selection of a bevel gearbox is governed by the following factors:

- Drive torque
- Drive speed (see dimensional tables)
- Duty cycle and drive power
- Forces and torque values acting on the ends of the shaft (please consult us in cases of doubt)

Required drive speed

The required drive speed is governed by the desired lifting speed, the transmission ratio of the jack and the transmission ratio of the other transmission components. A particular lifting speed can normally be achieved in several ways. Correct selection depends on the following criteria:

- Favorable efficiency
- Minimum load on transmission components in order to achieve compact, low-cost design
- Avoiding critical speeds for jack screws and connecting shafts

Jack screw nut torques

The nut torque (M) of the jack screw is the torque that the jack screw exerts on the mounting plate (all N versions except V), or the torque that the screw applies to the travelling nut (R version). It is not to be confused with the drive torque (M_T) of the screw jack gears on the worm shaft.

$$M \text{ [Nm]} = F_{\text{eff}} \text{ [kN]} \cdot f_M$$

(applicable in the areas of moderate and high loads)

M The jack screw nut torque in Nm for the "lift under load" movement.

F_{eff} The actual supported axial force in kN.

f_M A conversion factor that accounts for screw geometry and friction. The value is applicable under normal lubrication conditions. The higher value should be applied in the case of dry and static friction. In the case of ball screw drives, f_M is practically constant.

Size	f_M [Nm]	f_M [Nm]
	Trapezoidal	Ball Screw
MULI® 1	1.6	1.6
MULI® 2	1.8	1.6
MULI® 3	2.7	1.6
MULI® 4	3.4	1.6/3.2
MULI® 5	4.6	3.2
JUMBO® 1	5.5	-
JUMBO® 2	6.4	-
JUMBO® 3	7.2	3.2
JUMBO® 4	8	-
JUMBO® 5	10.6	-

Outline drawing and table of dimensions

Versions N, V

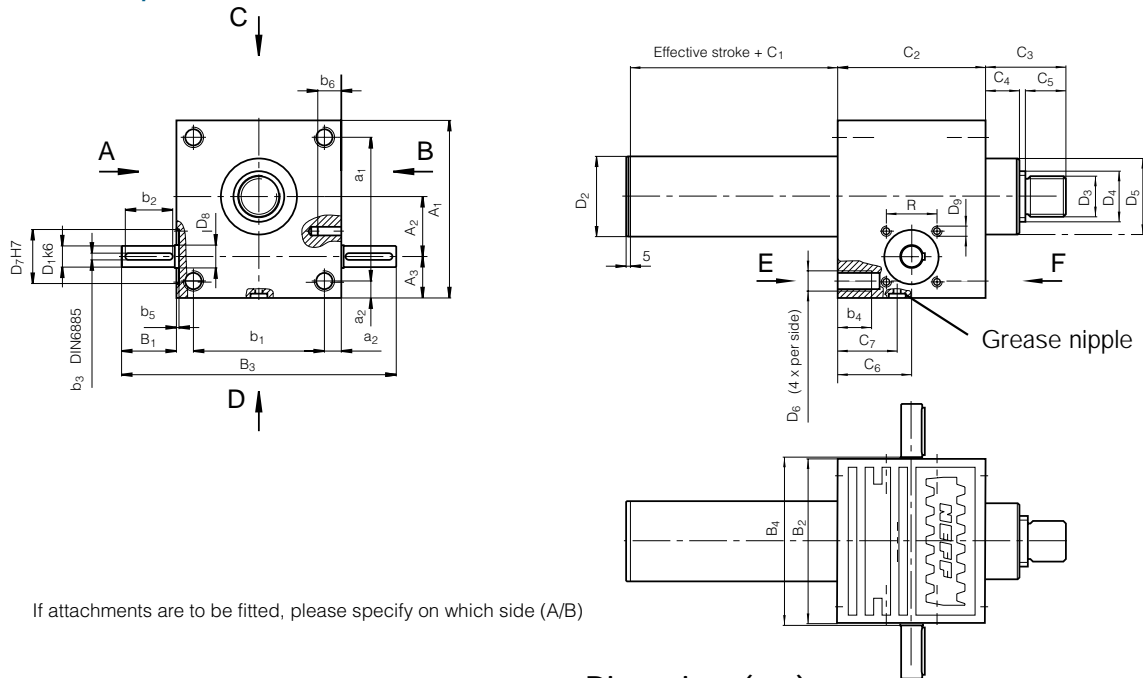

Size

Dimensions (mm)

	A1 ⁵⁾ Metric	A2 Metric	A3 Metric	a1 Metric	a2 Metric	B1 Metric	B2 Metric	B3 Metric	B4 Metric	b1 Metric	b2 Metric	b3 Metric	b4 Metric	b5 Metric	C1 Metric	C2 Metric	C3 ¹⁾ Metric
MULI® 1	80	25	24	60	10	24	72	120	77	52	18	3	13	1.5	20	62	35(46)
MULI® 2	100	32	28	78	11	27.5	85	140	90	63	20	5	15	1.5	30	75	45(48.5)
MULI® 3	130	45	31	106	12	45	105	195	110	81	36	5	15	2	30	82	50
MULI® 4	180	63	39	150	15	47.5	145	240	150	115	36	6	16	2	45	117	65
MULI® 5	200	71	46	166	17	67.5	165	300	170	131	56	8	30	2.5	55	160	95
JUMBO® 1	210	71	49	170	20	65	195	325	200	155	56	8	40	8	55	175	95
JUMBO® 2	240	80	60	190	25	67.5	220	355	225	170	56	8	45	8	55	165	110
JUMBO® 3	240	80	60	190	25	67.5	220	355	225	170	56	8	45	8	55	165	110
JUMBO® 4	290	100	65	230	30	65	250	380	255	190	56	10	54	8	65	220	140
JUMBO® 5	360	135	75	290	35	100	300	500	305	230	90	14	80	8	90	266	200

Size

Dimensions (mm)

	C4 ²⁾ Metric	C5 Metric	C6 Metric	C7 Metric	D1k6 ⁴⁾ Metric	D2 ³⁾ Metric	D3 ⁶⁾ Metric	D4Tr Metric	D4KGT Metric	D5 ²⁾ Metric	D6 Metric	D7H7 Metric	D8 Metric	D9x6 ⁷⁾ Metric	R(TK) ⁷⁾ Metric	V-KGT Metric
MULI® 1	12(23)	19	31	22	10 X 21.5	33	M12 X 1.75	Tr18 x 4	1605	29.6(48)	M8	28	12	M5 x 10	32(45.25)	30 x 30
MULI® 2	18(21.5)	20	37.5	27	14 X 25	40	M14 X 2.0	Tr20 x 4	2005	38.7(61)	M8	35	15	M6 x 12	35(49.5)	40 x 40
MULI® 3	23	22	41	29	16 X 42.5	50	M20 X 2.5	Tr30 x 6	2505	46	M10	35	17	M8 x 12	44(62.2)	50 x 50
MULI® 4	32	29	58.5	42.5	20 X 45	60	M30 X 3.5	Tr40 x 7	4005/4010	60	M12	52	25	M10 x 15	55(77.8)	60 x 60
MULI® 5	40	48	80	53	25 X 65	82	M36 X 4	Tr55 x 9	5010	85	M20	52	28	M12 x 18	60(84.85)	80 x 80
JUMBO® 1	40	48	87.5	60	25 X 62.5	90	M48 X 2	Tr60 x 9	-	90	M24	52	28	M12 x 18	60(84.85)	-
JUMBO® 2	40	58	82.5	60	30 X 65	115	M56 X 2	Tr70 x 10	-	105	M30	58	32	M12 x 18	(80)	-
JUMBO® 3	40	58	82.5	60	30 X 65	115	M64 X 3	Tr80 x 10	8010	120	M30	58	32	M12 x 18	(80)	120 x 120
JUMBO® 4	50	78	110	86	35 X 62.5	133	M72 X 3	Tr100 x 10	-	145	M36	72	40	M16 x 30	(100)	-
JUMBO® 5	60	118	133	109	48 X 97.5	153	M100 X 3	Tr120 x 14	-	170	M42	80	50	M16 x 40	(115)	-

1) This dimension refers to the closed height and represents a minimum. It must be increased if bellows are used (see page 34).

2) The values in brackets refer to version with ball screw.

3) Square tube for version with ball screw and anti-rotation device.

4) Diameter and length to shoulder.

5) Dimension A1 in accordance to DIN 1685 GTB 18.

6) In accordance to DIN 13 screw thread: MULI®. In accordance to DIN 13 fine pitch thread: JUMBO®.

7) JUMBO® 2 – JUMBO® 5, only 3 holes are present.

Outline drawing and table of dimensions

Version R

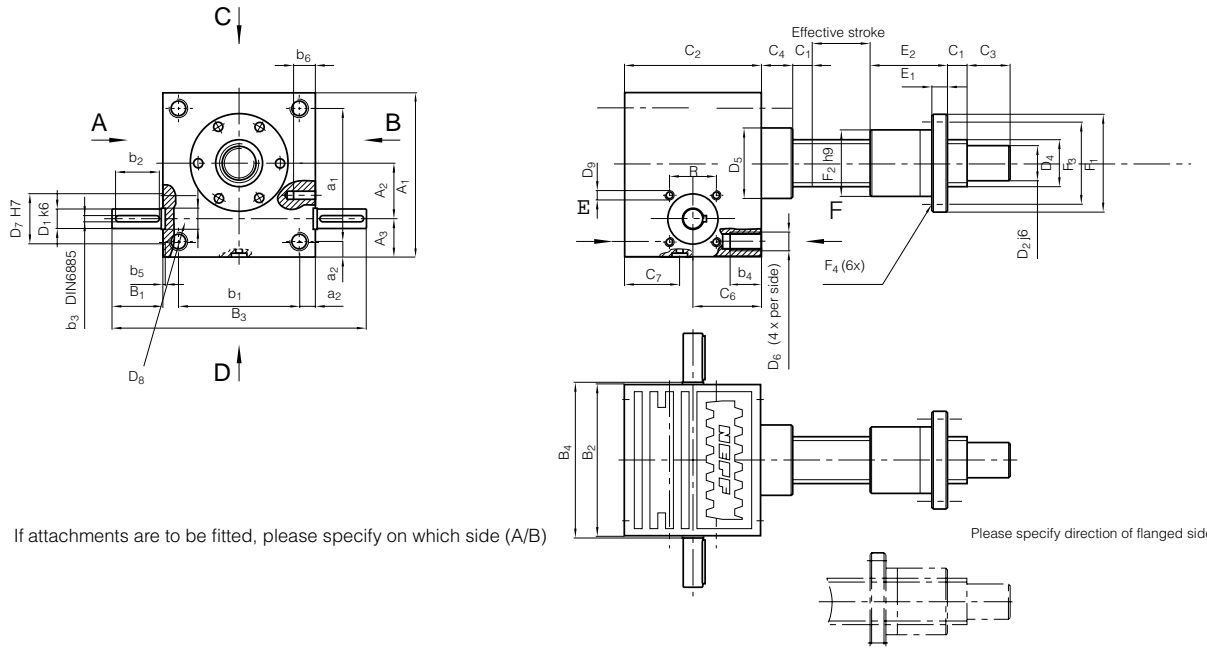

If attachments are to be fitted, please specify on which side (A/B)

Please specify direction of flanged side

Size

Dimensions (mm)

	A ₁	A ₂	A ₃	a ₁	a ₂	B ₁	B ₂	B ₃	B ₄	b ₁	b ₂	b ₃	b ₄	b ₅	C ₁	C ₂	C ₃	C ₄	C ₆	C ₇	
	Metric	Metric	Metric	Metric	Metric	Metric	Metric	Metric	Metric	Metric	Metric	Metric	Metric	Metric	Metric	Metric	Metric	Metric	Metric	Metric	Metric
MULI® 1	80	25	24	60	10	24	72	120	77	52	18	3	13	1.5	12	62	15	12	31	22	
MULI® 2	100	32	28	78	11	27.5	85	140	90	63	20	5	15	1.5	15	75	20	18	37.5	27	
MULI® 3	130	45	31	106	12	45	105	195	110	81	36	5	15	2	20	82	25	23	41	29	
MULI® 4	180	63	39	150	15	47.5	145	240	150	115	36	6	16	2	25	117	30	32	58.5	42.5	
MULI® 5	200	71	46	166	17	67.5	165	300	170	131	56	8	30	2.5	25	160	45	40	80	53	
JUMBO® 1	210	71	49	170	20	65	195	325	200	155	56	8	40	8	25	175	55	40	87.5	60	
JUMBO® 2	240	80	60	190	25	67.5	220	355	225	170	56	8	45	8	25	165	70	40	82.5	60	
JUMBO® 3	240	80	60	190	25	67.5	220	355	225	170	56	8	45	8	25	165	75	40	82.5	60	
JUMBO® 4	290	100	65	230	30	65	250	380	255	190	56	10	54	8	25	220	100	50	110	86	
JUMBO® 5	360	135	75	290	35	100	300	500	305	230	90	14	80	8	30	266	120	60	133	109	

Size

Dimensions (mm)

	D _{1k6} ³⁾	D ₂	D _{4TR}	D _{4KGT}	D ₅ ²⁾	D ₆	D _{7H7}	D ₈	D _{9xb6}	R(TK)	E ₁ ¹⁾	E ₂ ¹⁾	F ₁ ¹⁾²⁾	F ₂ ¹⁾²⁾	F ₃ ¹⁾²⁾	F ₄ ¹⁾²⁾
	Metric	Metric	Metric	Metric	Metric	Metric	Metric	Metric	Metric	Metric	Metric	Metric	Metric	Metric	Metric	Metric
MULI® 1	10 x 21.5	12	Tr18 x 4	1605	29.6/48	M8	28	12	M5x10	32(45.25)	12/12	44/44	48/48	28/28	38/38	6/5.5
MULI® 2	14 x 25	15	Tr20 x 4	2005	38.7/61	M8	35	15	M6x12	35(49.5)	12/12	44/44	55/55	32/32	45/45	7/7
MULI® 3	16 x 42.5	20	Tr30 x 6	2505	46	M10	35	17	M8x12	44(62.2)	14/14	46/46	62/62	38/38	50/50	7/7
MULI® 4	20 x 45	25	Tr40 x 7	4005/4010	60	M12	52	25	M10x15	55(77.8)	16/16	73/59	95/80	63/53	78/68	7/9
MULI® 5	25 x 65	40	Tr55 x 9	5010	85	M20	52	28	M12x18	60(84.85)	18/18	97/97	110/110	72/72	90/90	11/11
JUMBO® 1	25 x 62.5	45	Tr60 x 9	---	90	M24	52	28	M12x18	60(84.85)	20	99	125	85	105	11
JUMBO® 2	30 x 65	55	Tr70 x 10	---	105	M30	58	32	M12x18	(80)	30	100	180	95	140	17
JUMBO® 3	30 x 65	60	Tr80 x 10	8010	120	M30	58	32	M12x18	(80)	30/22	110/101	190/145	105/105	150/125	17/14
JUMBO® 4	35 x 62.5	80	Tr100 x 10	---	145	M36	72	40	M16x30	(100)	35	130	240	130	185	25
JUMBO® 5	48 x 97.5	95	Tr120 x 14	---	170	M42	80	50	M16x40	(115)	40	160	300	160	230	28

1) The first values in the table apply to the trapezoidal screw nut EFM. For dimension 4010 the first values in the table are valid.

2) The second values in the table apply to the ball screw nut KGF.

3) Diameter and length to shoulder.

4) Dimension A1 in accordance with DIN 1685 GTB 18.

Accessories

Trapezoidal screw nuts

Preassembled bronze nut EFM

For drive units in continuous operation with particularly good wear properties. Can be used as safety nut and are sea water resistant in combination with stainless screws. EFM nuts have the same dimensions as ball screw nuts KGF-N and can be fitted together with the nut mountings KON-N and KAR-N (see accessories).

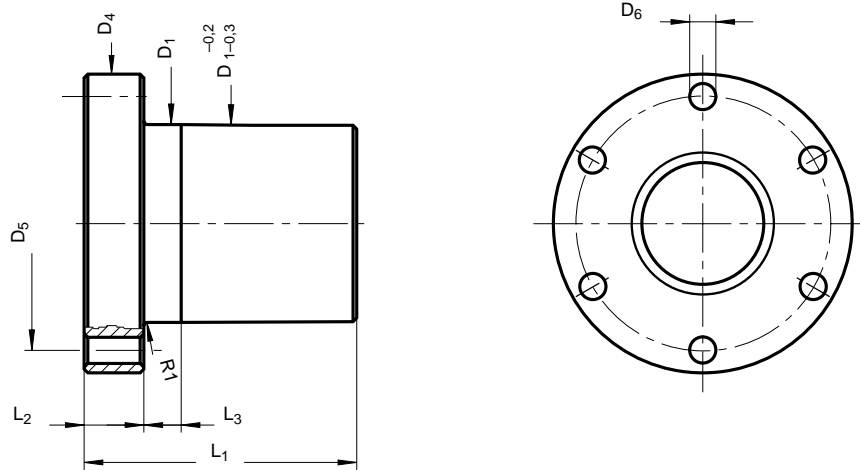

Size	Product / Size	Dimensions (mm)								
		D ₁ Metric	D ₄ Metric	D ₅ Metric	6xD ₆ Metric	L ₁ Metric	L ₂ Metric	L ₃ Metric	L ₄ Metric	L ₅ Metric
MULI® 1	EFM Tr 18 x 4	28	48	38	6	44	12	8	15	22
MULI® 2	EFM Tr 20 x 4	32	55	45	7	44	12	8	15	25
MULI® 3	EFM Tr 30 x 6	38	62	50	7	46	14	8	20	25
MULI® 4	EFM Tr 40 x 7	63	95	78	9	73	16	10	20	35
MULI® 5	EFM Tr 55 x 9	72	110	90	11	97	18	10	20	40
JUMBO® 1	EFM Tr 60 x 9	85	125	105	11	99	20	10	20	40
JUMBO® 2	EFM Tr 70 x 10	95	180	140	17	100	30	16	20	40
JUMBO® 3	EFM Tr 80 x 10	105	190	150	17	110	30	16	20	40
JUMBO® 4	EFM Tr 100 x 10	130	240	185	25	130	35	16	20	50
JUMBO® 5	EFM Tr 120 x 14	160	300	230	28	160	40	20	20	55

Adapter for attachment of the second bellows

Version R only

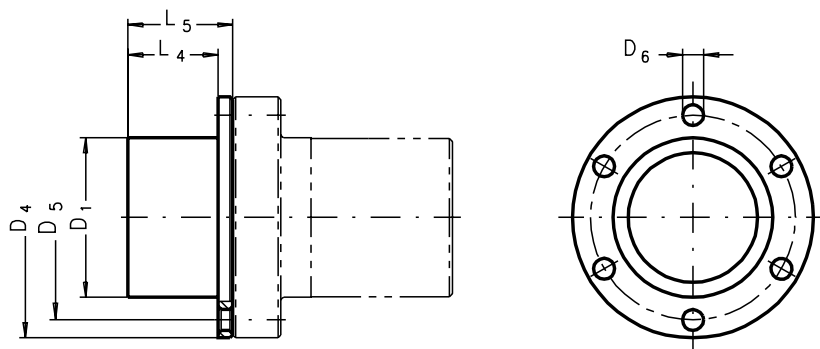

Accessories

Ball screw nuts

Flanged ball screw nut KGF

Flanged ball screw nut with mounting and lubrication holes and with profiled gaskets (reduces lubricant leakage and prevents ingress of dirt particles) for ball screw KGS.

Zero-backlash units KGT-FF/KGT-MM/KGT-FM

Factory adjusted and assembled combinations of two cylindrical nuts (MM), two flanged nuts (FF) or one flanged and one cylindrical nut (FM).

Only available as screw mechanism, i.e. nut preassembled on the corresponding ball screw.

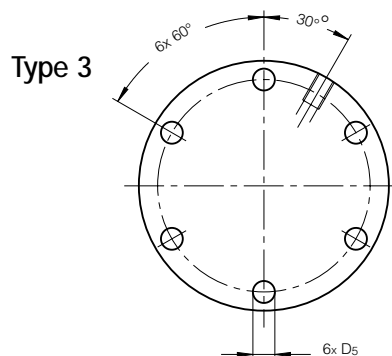
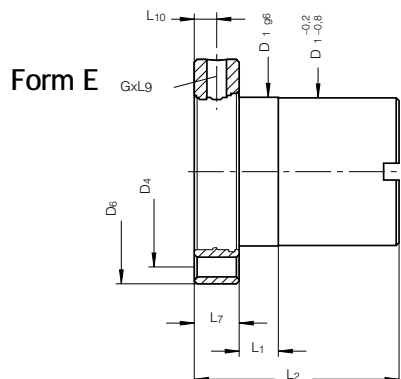

Size	Product / Size	Dimensions (mm)												Max. Axial Backlash	Number of Reversals	C ²⁾ kN	C ³⁾ kN	C ₀ = C _{0a} kN
		D ₁ Metric	D ₄ Metric	D ₅ Metric	D ₆ Metric	L ₁ Metric	L ₂ Metric	L ₄ Metric	L ₅ Metric	L ₇ Metric	L ₉ Metric	L ₁₀ Metric	G Metric					
MULI [®] 1	KGF 1605 RH-EE(4)	28	38	5.5	48	8	44	15	22	12	8	6	M6	0.08	3	12.0	7.0	12.7
MULI [®] 2	KGF 2005 RH-EE(4)	32	45	7	55	8	44	15	25	12	8	6	M6	0.08	3	14.0	8.0	17.0
MULI [®] 3	KGF 2505 RH-EE(4)	38	50	7	62	8	46	20	25	14	8	7	M6	0.08	3	15.0	9.5	22.4
MULI [®] 4	KGF 4005 RH-EE(4)	53	68	7	80	10	59	20	35	16	8	8	M6	0.08	5	26.0	19.0	63.5
MULI [®] 5	KGF 4010 RH-EE(4)	63	78	9	95	10	73	20	35	16	8	8	M8x1	0.08	3	50.0	30.0	70.0
JUMBO [®] 1	KGF 5010 RH-EE(4)	72	90	11	110	10	97	20	40	18	8	9	M8x1	0.08	5	78.0	55.0	153.0
JUMBO [®] 3	KGF 8010 RH-EE(4)	105	125	14	145	10	101	20	40	22	8	11	M8x1	0.08	5	93.0	69.0	260.0

1) Only 75% of the specified values are permitted for a pitch accuracy of 200 µm/300 mm screw length.

2) Dynamic load rating to DIN 69051 Part 4, draft version 1978.

3) Dynamic load rating to DIN 69051 Part 4, draft version 1989.

4) EE = rubber wiper

Adapter for attachment of the second bellows

Version R only

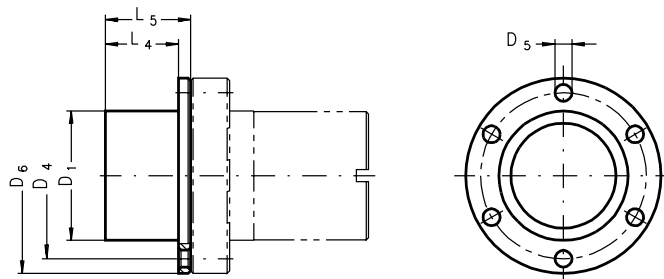

Accessories

Mountings

Trunnion nut mountings KAR

Trunnion nut mounting for trunnion mounting of the flanged ball screw nut KGF and flanged trapezoidal screw nut EFM.

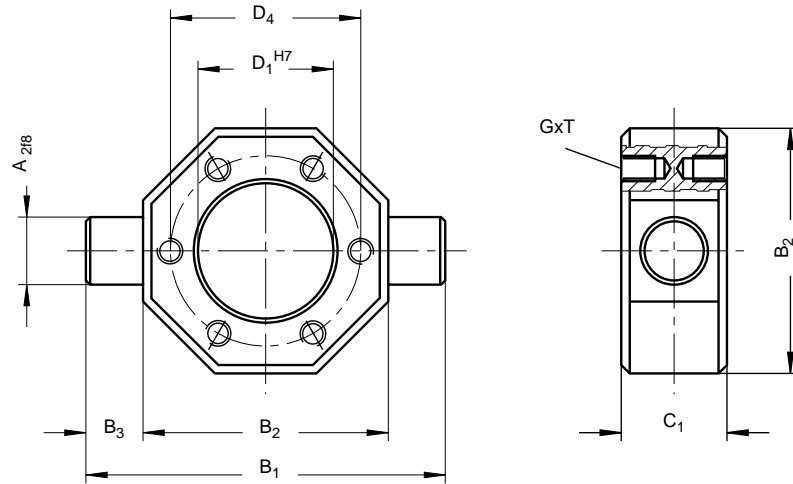

Mounting feet L

Supplied loose with mounting bolts for jack.

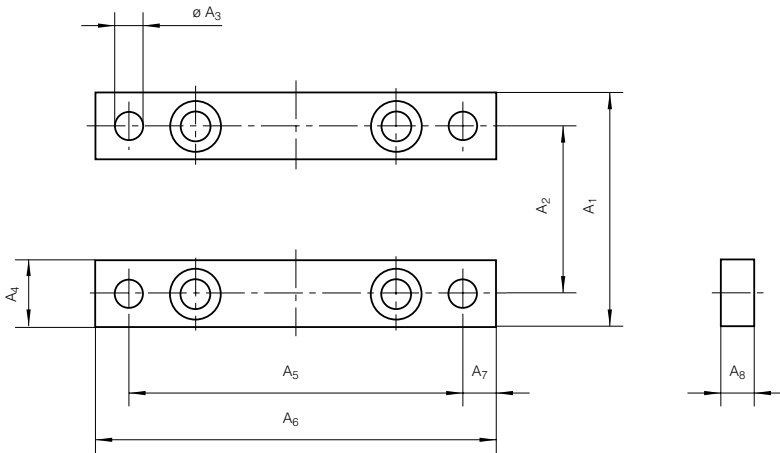

Trunnion mountings K

Supplied loose with mounting bolts for jack.

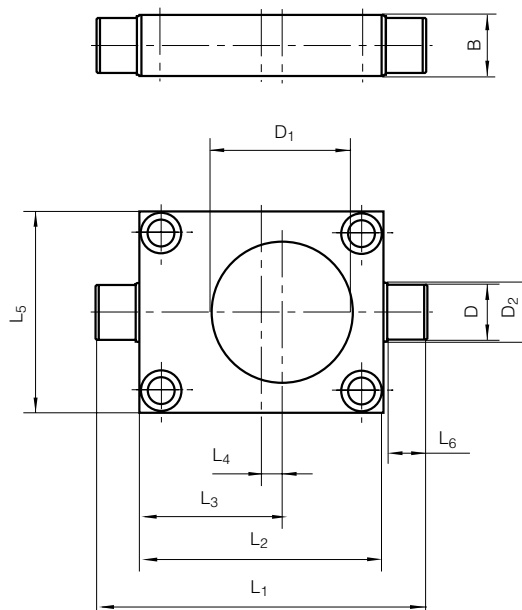

Accessories

Mountings

Size	Type		Dimensions (mm)									Weight [kg]
	for KGF	for EFM	A ₂	B ₁	B ₂	B ₃	C ₁	D ₁	D ₄	G x T		
KAR MULI® 1	KAR 1605	Tr 16x4/Tr 18x4	12	70	50	10	20	28	38	M 5x10	0.2	
KAR MULI® 2	KAR 2005	Tr 20x4/Tr 24x4	16	85	58	13.5	25	32	45	M 6x12	0.3	
KAR MULI® 3	KAR 2505	Tr 30x6	18	95	65	15	25	38	50	M 6x12	0.5	
KAR MULI® 4	KAR 4005		25	125	85	20	30	53	68	M 6x12	1.2	
	KAR 4010	Tr 40x7	30	140	100	20	40	63	78	M 8x14	2.5	
KAR MULI® 5	KAR 5010	Tr 55x9	40	165	115	25	50	72	90	M10x16	2.8	
KAR JUMBO® 1	KAR 6310	Tr 60x9	40	180	130	25	50	85	105	M10x16	3.3	
KAR JUMBO® 3	KAR 8010		50	200	150	25	60	105	125	M12x18	4.8	

Size	Dimensions (mm)									Weight [kg]
	A ₁	A ₂	A ₃	A ₄	A ₅	A ₆	A ₇	A ₈		
L MULI® 1	72	52	8.5	20	100	120	10	10	0.3	
L MULI® 2	85	63	8.5	20	120	140	10	10	0.4	
L MULI® 3	105	81	11	24	150	170	10	12	0.8	
L MULI® 4	145	115	13.5	30	204	230	13	16	1.7	
L MULI® 5	171	131	22	40	236	270	17	25	3.9	
L JUMBO® 1	205	155	26	50	250	290	20	30	5.8	
L JUMBO® 2	230	170	32	65	290	340	25	40	10	
L JUMBO® 3	230	170	32	65	290	340	25	40	10	
L JUMBO® 4	270	190	39	80	350	410	30	50	20.8	
L JUMBO® 5	330	230	45	100	430	500	35	60	34.4	

Size	Dimensions (mm)										Weight [kg]
	L ₁	L ₂	L ₃	L ₄	L ₅	L ₆	D _{f8}	D ₁	D ₂	B	
K MULI® 1	110	80	49	9	72	13	15	44	18	20	0.76
K MULI® 2	140	100	60	10	85	18	20	58	23	25	1.44
K MULI® 3	170	130	76	11	105	18	25	72	28	30	2.8
K MULI® 4	240	180	102	12	145	28	35	86	38	40	7.4
K MULI® 5	270	200	117	17	165	33	45	115	48	50	10.72
K JUMBO® 1	290	210	120	15	195	38	50	130	56	60	11.8
K JUMBO® 2	330	240	140	20	220	43	70	170	76	80	26.1
K JUMBO® 3	330	240	140	20	220	43	70	170	76	80	26.1
K JUMBO® 4	410	290	165	20	250	58	80	160	88	90	40.2
K JUMBO® 5	520	360	210	30	300	78	90	175	96	100	67.7

Accessories

Attachments

Top plate BP

Screwed onto the mounting thread of the jack screw and protected against rotation.

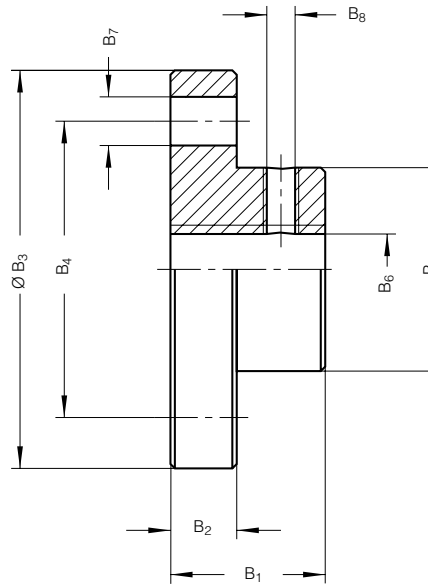

Fork end GA

Screwed onto the mounting thread of the jack screw and protected against rotation. Supplied with split pins and collar pins. Galvanized.

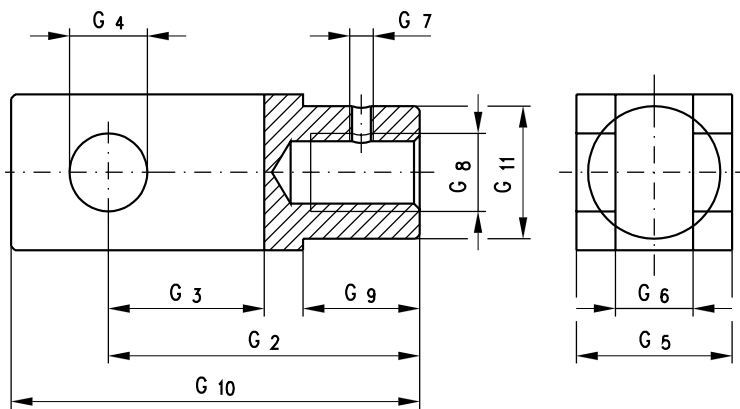

Clevis end GK

Screwed onto the mounting thread of the jack screw and protected against rotation.

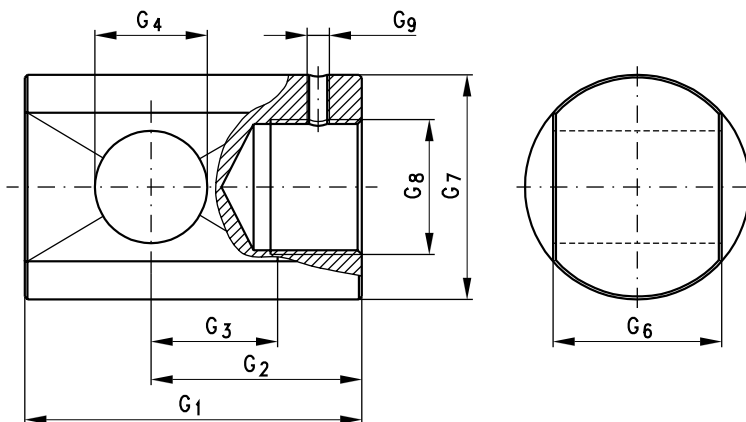

Accessories

Attachments

Size

Dimensions (mm)

	B ₁	B ₂	ØB ₃	B ₄	B ₅	B ₆	B _{7x4}	B ₈	Weight [kg]
BP MULI® 1	20	7	65	48	29.3	M12	9	M5	0.2
BP MULI® 2	21	8	80	60	38.7	M14	11	M6	0.3
BP MULI® 3	23	10	90	67	46	M20	11	M8	0.6
BP MULI® 4	30	15	110	85	60	M30	13	M8	1.2
BP MULI® 5	50	20	150	117	85	M36	17	M10	4.8
BP JUMBO® 1	50	25	170	130	90	M48x2	21	M10	5
BP JUMBO® 2	60	30	200	155	105	M56x2	25	M12	7.7
BP JUMBO® 3	60	30	220	170	120	M64x3	25	M12	9.8
BP JUMBO® 4	80	40	260	205	145	M72x3	32	M12	18.4
BP JUMBO® 5	120	40	310	240	170	M100x3	38	M12	29.6

Size

Dimensions (mm)

	G ₂	G ₃	G ₄ (h9 tolerance)	G ₅	G ₆ (h12 tolerance)	G ₇	G ₈	G ₉	G ₁₀	G ₁₁	Weight [kg]
GA MULI® 1	48	24	12	24	12	115	M12	18	62	20	0.15
GA MULI® 2	56	28	14	28	14	116	M14	22	72	24.5	0.2
GA MULI® 3	80	40	20	40	20	118	M20	30	105	34	0.8
GA MULI® 4	120	60	30	60	30	118	M30	43	160	52	2.5
GA MULI® 5	144	72	35	70	35	1110	M36	40	188	60	3.8

Size

Dimensions (mm)

	G ₁	G ₂	G ₃	G ₄ (h8 tolerance)	G ₆ (h10 tolerance)	G ₇	G ₈	G ₉	Weight [kg]
GK MULI® 1	55	40	15	10	15	30	M12	115	0.2
GK MULI® 2	63	45	18	12	20	39	M14	116	0.3
GK MULI® 3	78	53	20	16	30	45	M20	118	0.6
GK MULI® 4	100	70	30	20	35	60	M30	118	1.2
GK MULI® 5	130	97	33	22	40	85	M36	1110	2.5
GK JUMBO® 1	120	75	45	40	60	90	M48x2	1110	4.8
GK JUMBO® 2	130	90	50	50	70	105	M56x2	1112	4.8
GK JUMBO® 3	155	105	60	60	80	120	M64x3	1112	8
GK JUMBO® 4	220	135	85	80	110	145	M72x3	1112	22.5
GK JUMBO® 5	300	200	100	90	120	170	M100x3	1112	31.5

Accessories

Attachments

Bellows F

Length: For each 150 mm of open length up to 1.80 m, allow 8 mm when calculating the closed length. Allow 10 mm for each 150 mm over 1.80 m. The calculated length is added to value C3 (see page 26) as screw extension.

Diameter F2 may differ on the opposite side, depending on the attachment fitted.

Important: The installation position must be specified, as internal support rings must be fitted when the jack is operated in a horizontal position. When installed vertically, bellows over 2 meters have textile tapes.

The same information is also required for the second bellows when ordering version R (rotating screw).

Material: PVC-coated polyester, stitched construction. Temperature range -30 °C to 70 °C. Secured in position by clamping rings. Special versions on request.

Flat spiral spring covers SF

Available on request (refer also to the catalog: Screw drives GT, KOKON®).

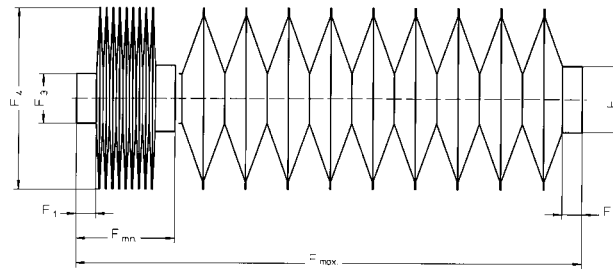

Size

Dimensions (mm)

	Jack Type	F ₁	F ₂	F ₃	F ₄
F MULI® 1	N/V TGS(1)	12	30	30	101
	N/V KGS(1)	12	48	30	101
	R	12	30	28	101
F MULI® 2	N/V TGS(1)	12	39	39	113
	N/V KGS(1)	12	61	39	113
	R	12	39	32	113
F MULI® 3	N/V	20	46	46	127
	R	20	46	38	127
F MULI® 4	N/V	20	60	60	140
	R TGS/KGS-4010(1)	20	60	63	140
	R KGS-4005(1)	20	60	53	140
F MULI® 5	N/V	20	85	85	152
	R	20	85	72	152
F JUMBO® 1	N/V	20	90	90	165
	R	20	90	85	165
F JUMBO® 2	N/V	20	105	105	175
	R	20	105	95	175
F JUMBO® 3	N/V	20	120	120	191
	R	20	120	105	191
F JUMBO® 4	N/V	20	145	145	201
	R	20	145	130	201
F JUMBO® 5	N/V	20	170	170	245
	R	20	170	160	245

1) TGS = Trapezoidal screw

KGS = Ball screw

Accessories

Protection

Limit switches with roller lever

Particularly suitable for end-position shutoff (also available in explosion-proof design).

Actuating cam 30° in accordance with DIN 69 639:

Ve (Approach velocity):
0.001 to 0.1 m/s

Connection:

5-core cable with PVC sheath, 1m long
Conductor cross-section
0.75 mm²
Brown/blue: NO contact
Black/black: NC contact
Green/yellow: PE conductor

A (Minimum actuating stroke):
2.6 ± 0.5 mm

B (Differential stroke):
0.85 ± 0.25 mm

FO (Minimum switch-on force):
1 N

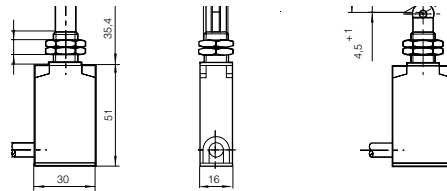

Switching capacity: NF C 63 146
(IEC 947-5-1)
Ident No. 92203259

Limit switch installation position

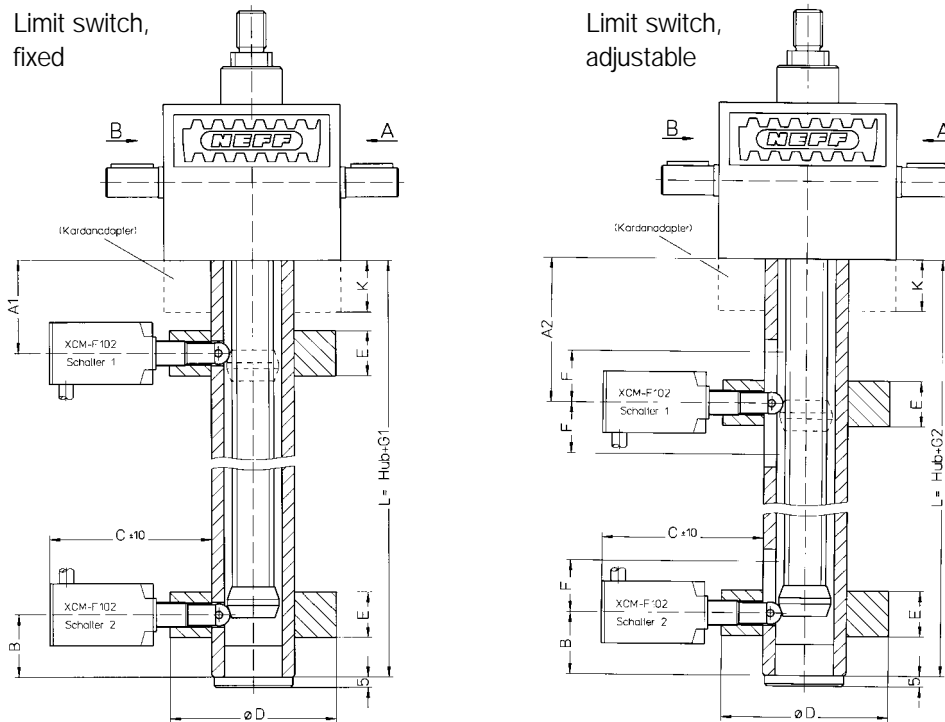

Size

Dimensions (mm)

	A ₁	A ₂	B	C	ØD	E	F	G ₁	G ₂	K
MULI® 1	40	65	30	80	80	20	25	82	107	20
MULI® 2	45	70	30	80	80	20	25	87	112	25
MULI® 3	50	75	30	80	90	20	25	92	117	30
MULI® 4	60	85	30	80	100	20	25	102	127	40
MULI® 5	70	95	30	80	120	20	25	112	137	50
JUMBO® 1	80	105	30	80	140	20	25	122	147	60
JUMBO® 2	100	125	30	80	160	20	25	142	167	80
JUMBO® 3	100	125	30	80	160	20	25	142	167	80
JUMBO® 4	110	135	30	80	170	20	25	152	177	90
JUMBO® 5	120	145	30	80	190	20	25	162	187	100

Accessories

Safety nuts

Safety nuts SFM-TGS/KGS(1)

For version R: The safety nut is positioned below the travelling nut without axial load and is therefore not subjected to wear. The functioning of the safety nuts is guaranteed only when installation and applied forces are as shown in the illustration (see below). As the travelling nut wears, the distance "x" between the two nuts decreases, which provides a visual check of wear without the need for dismantling.

The travelling nut must be replaced when the axial play on a single-thread screw is more than 25% of the lead of the thread (dimension X). Otherwise, safety cannot be guaranteed.

Wear greater than 25% of the lead of the thread can endanger persons and property. Dimension X must be checked regularly.

The safety nut supports the load if the thread form of the travelling nut fails as a result of excessive wear (dirt, lubrication starvation, overheating, etc.). The safety nut can only be ordered together with the flanged nut (we reserve the right to make design changes).

For version N: The design is similar to that for version R. A visual check for wear is also possible in this case. Please specify the load direction when ordering.

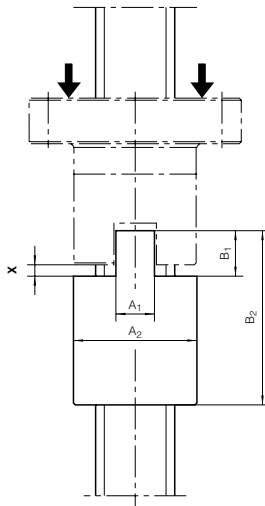

Size

Dimensions (mm)

	A ₁	A ₂ (-0.5)	B ₁	B ₂	X	Weight [kg]
SFM MULI® 1	10	28	10	44	1	0.45
SFM MULI® 2	10	32	10	44	1	0.55
SFM MULI® 3	12	38	10	46	1.5	0.7
SFM MULI® 4	16	63	15	73	1.75	3.1
SFM MULI® 5	20	72	16	97	2.25	4.3
SFM JUMBO® 1	20	85	16	99	2.25	5.7
SFM JUMBO® 2	25	95	20	100	2.5	11.3
SFM JUMBO® 3	25	105	20	110	2.5	13.7
SFM JUMBO® 4	30	130	25	130	2.5	23.3
SFM JUMBO® 5	40	160	25	160	3.5	45.7

1) KGS on request.

Cubic face screw jacks

Screw jack accessories

These and other accessories are available upon request. Please ask any of our technical sales representatives.

Motor adaptor flanges MG

Motor adaptor flanges are used to mount motors to worm gear screw jacks and house the coupling for connecting the motor to the drive shaft.

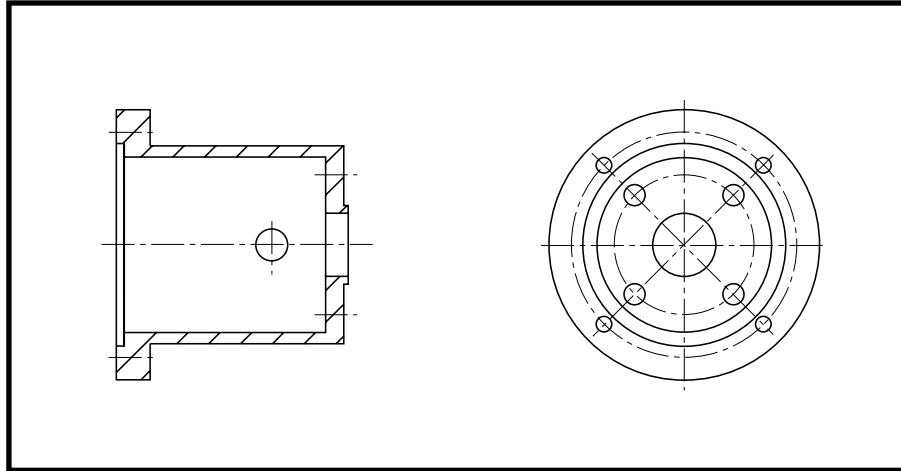

Flexible couplings

Flexible couplings provide impact proof transmission of torque and compensate for axial offset and displacements and for angular alignment errors.

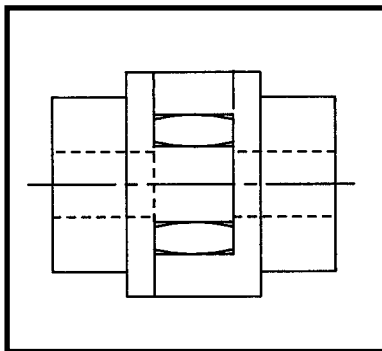

Pillow blocks

Pillow blocks are used to support drive shafts, where required.

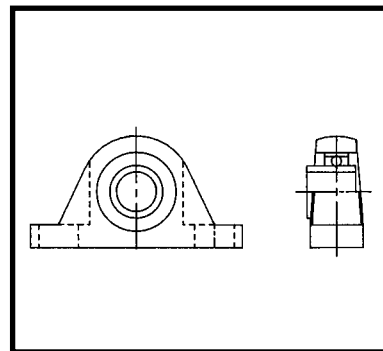

Drive shafts

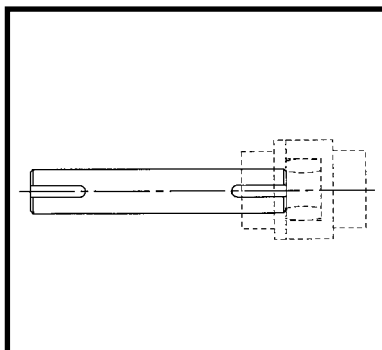

Handwheels

Handwheels allow manual screw jack operation.

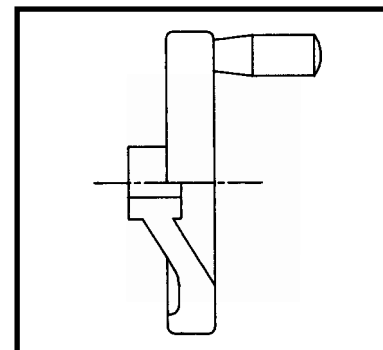

Application checklist: Maryland Metrics

MULI[®], JUMBO[®] cubic screw jacks

Contact		Job Title		Date	
Company				Ref.	
Address				Tel.	
				Fax.	
Company sector of activity					

Details of application

PERFORMANCE REQUIREMENTS	
<p>Load :</p> <p>Dynamic (kN)(ton) Static (kN)(ton)</p> <p>Compression <table border="1" style="display: inline-table; width: 150px; height: 20px;"></table></p> <p>Tension <table border="1" style="display: inline-table; width: 150px; height: 20px;"></table></p> <p>Load (kN)(ton) on : Jack <input type="checkbox"/> Jack <input type="checkbox"/> Jack <input type="checkbox"/> Jack <input type="checkbox"/></p> <p>Load type : Constant <input type="checkbox"/> Oscillating <input type="checkbox"/> Reversing <input type="checkbox"/></p> <p>Shock <input type="checkbox"/> Vibration <input type="checkbox"/></p>	<p>Jack duty :</p> <p>Jack operating time (mins) <table border="1" style="display: inline-table; width: 60px; height: 20px;"></table></p> <p>Elapsed cycle time (mins) <table border="1" style="display: inline-table; width: 60px; height: 20px;"></table></p> <p>No. of cycles per day <table border="1" style="display: inline-table; width: 60px; height: 20px;"></table></p> <p>No. of working days per year <table border="1" style="display: inline-table; width: 60px; height: 20px;"></table></p> <p>No. of years <table border="1" style="display: inline-table; width: 60px; height: 20px;"></table></p>
<p>Other :</p> <p>Linear speed (mm/min)(in/min) <table border="1" style="display: inline-table; width: 60px; height: 20px;"></table></p> <p>Stroke length (mm)(in) <table border="1" style="display: inline-table; width: 60px; height: 20px;"></table></p> <p>Positional accuracy (mm)(in) <table border="1" style="display: inline-table; width: 60px; height: 20px;"></table></p> <p>Mounting : Vertical <input type="checkbox"/> Horizontal <input type="checkbox"/></p>	<p>Operating environment :</p> <p>Ambient temperature (°C)(°F) <table border="1" style="display: inline-table; width: 60px; height: 20px;"></table></p> <p>Check if applicable :</p> <p>High Humidity <input type="checkbox"/></p> <p>Dusty <input type="checkbox"/></p> <p>Wet <input type="checkbox"/></p> <p>Corrosive <input type="checkbox"/></p> <p>Radioactive <input type="checkbox"/></p> <p>Other please specify <table border="1" style="display: inline-table; width: 150px; height: 20px;"></table></p>

BASIC JACK VERSION		
Upright <input type="checkbox"/>	Translating <input type="checkbox"/>	Keyed feature <input type="checkbox"/>
Inverted <input type="checkbox"/>	Rotating <input type="checkbox"/>	Anti-backlash feature <input type="checkbox"/>

JACK ACCESSORIES		
Top plate <input type="checkbox"/>	Trunnion mounting <input type="checkbox"/>	Fixed limit switches <input type="checkbox"/>
Clevis end <input type="checkbox"/>	Bellow (PVC) <input type="checkbox"/>	Adjustable limit switches <input type="checkbox"/>
Fork end <input type="checkbox"/>	Bellow (heat resistant) <input type="checkbox"/>	

DRIVES AND DRIVE COMPONENTS		
AC motor <input type="checkbox"/>	Motor adaptor flange <input type="checkbox"/>	Drive shaft <input type="checkbox"/>
DC motor <input type="checkbox"/>	Bevel gearbox <input type="checkbox"/>	Pillow block <input type="checkbox"/>
Specify ___V/___Ph/___Hz/IP___	coupling	Handwheel <input type="checkbox"/>
Other motor type <table border="1" style="display: inline-table; width: 100px; height: 20px;"></table>		

Please complete and fax, along with a sketch of the installation, to Maryland Metrics at (410)358-3142 or (800)872-9329

How to order MULI®/JUMBO®

Configuration of the order code:

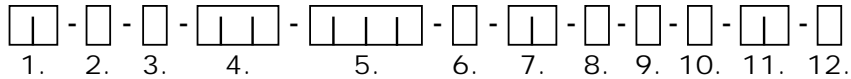

- | | | |
|---|--|---|
| 1. Size
M1 – M5
J1 – J5 | 7. End fitting
0 = Without
BP = Top plate
GA = Fork end
GK = Clevis end | 11. Special features
0 = Without
Z = Standard accessories as per catalog, for direct mounting on the gears (attachment strips, motor, motor adapter flange with coupling) |
| 2. Version
N
R
V | 8. Bellows
0 = Without
F = With bellows | S = Special accessories, or accessories for constructional alterations to the standard version (special screw, special screw end) alignment GK/GA in V Version |
| 3. Gear ratio
H
L | 9. Nut
0 = Without
1 = EFM (trapezoidal)
2 = KGF (flanged ball screw nut)
3 = KGM (cylindrical ball screw nut) | 12. Screw dimensions
MULI® 4-KGS
0 = for all sizes except MULI® 4-KGS
1 = 4005
2 = 4010 |
| 4. Screw type
TGS (trapezoidal screw)
KGS (ball screw) | 10. Stop collar
0 = Without
A = With | |
| 5. Stroke
[mm] | | |
| 6. Stroke end
G = Standard screw D3
Z = With cylindrical end D _{2j6}
0 = No end machining
S = Special end (as specified by customer) | | |

Example order code:

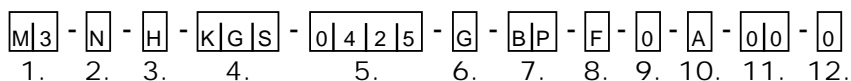

- | | | |
|----------------------|------------------------------------|---|
| 1. Size
MULI® 3 | 6. Screw end
Standard thread D3 | 11. Special features
Without |
| 2. Version
N | 7. End fitting
BP = Top plate | 12. Screw dimensions
MULI® 4-KGS
0 = for all sizes except MULI® 4-KGS |
| 3. Gear ratio
H | 8. Bellows
With bellows | |
| 4. Screw type
KGS | 9. Nut
Without | |
| 5. Stroke
425 mm | 10. Stop collar
With | |

Notes



Call us today and one of the factories product engineers will be eager to show you how Maryland Metrics can solve your complex applications problems with innovative engineering solutions.

Maryland Metrics P.O.Box 261 Owings Mills, MD 21117 USA

Phones: (410)358-3130 (800)638-1830 Faxes: (410)358-3142 (800)872-9329

E-Mail: techinfo@mdmetric.com URL: <http://mdmetric.com>

Product catalogs, sizing software, and technical notes available.

Subsidiaries of Precision Technology Group, Limited

- Precision Technology USA, Inc
- Neff® Antriebstechnik Automation GmbH in Waldenbuch, Germany
 - Graessner GmbH in Dettenhausen, Germany
- Precision Actuation Systems in Blantyre, Scotland

These products are available from:

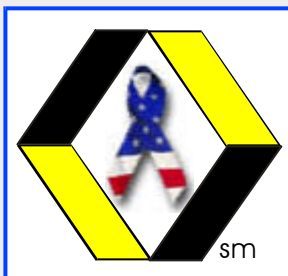

MARYLAND METRICS

phones: (800) 638-1830 (410) 358-3130
faxes: (800) 872-9329 (410)358-3142

E-mail: sales@mdmetric.com URL: <http://mdmetric.com>

P.O.Box 261 Owings Mills, MD21117USA
6119 Oakleaf Avenue Baltimore, MD21215USA